



Standard Test Methods for Determining the Mechanical Properties of Externally and Internally Threaded Fasteners, Washers, Direct Tension Indicators, and Rivets¹

This standard is issued under the fixed designation F606/F606M; the number immediately following the designation indicates the year of original adoption or, in the case of revision, the year of last revision. A number in parentheses indicates the year of last reapproval. A superscript epsilon (ϵ) indicates an editorial change since the last revision or reapproval.

This standard has been approved for use by agencies of the U.S. Department of Defense.

1. Scope*

1.1 These test methods cover establishment of procedures for conducting tests to determine the mechanical properties of externally and internally threaded fasteners, washers, direct tension indicators, and rivets.

1.2 Property requirements and the applicable tests for their determination are specified in individual product standards. In those instances where the testing requirements are unique or at variance with these standard procedures, the product standard shall specify the controlling testing requirements. In the absence of any specified test requirement(s), these test methods shall apply.

1.3 These test methods describe mechanical tests for determining the following properties:

	Section
For Externally Threaded Fasteners:	3
Product Hardness	3.1
Proof Load	3.2.1
Method 1, Length Measurement	3.2.3
Method 2, Yield Strength	3.2.4
Method 3, Uniform Hardness	3.2.5
Axial Tension Testing of Full-Size Product	3.4
Wedge Tension Testing of Full-Size Product	3.5
Tension Testing of Machined Test Specimens	3.6
Total Extension at Fracture Test	3.7
Single Shear Test	3.8
For Internally Threaded Fasteners:	4
Product Hardness	4.1
Proof Load Test	4.2
Cone Proof Load Test	4.3
For Washers and Direct Tension Indicators:	5
Product Hardness-General Requirements	5.1
Through Hardened Washers	5.2
Carburized Washers	5.3
Stainless Steel and Nonferrous Washers	5.4
Direct Tension Indicators	5.5
Compression Load	5.6
For Rivets:	6

¹ These test methods are under the jurisdiction of ASTM Committee F16 on Fasteners and are the direct responsibility of Subcommittee F16.01 on Test Methods.

Current edition approved Sept. 1, 2016. Published September 2016. Originally approved in 1979. Last previous edition approved in 2014 as F606 – 14a^{ε1}. DOI: 10.1520/F0606_F0606M-16.

Product Hardness	6.1
Test for Embrittlement of Metallic-Coated Externally Threaded Fasteners	7
Test Method for Determining Decarburization and Carburization	8

1.4 The values stated in either SI units or inch-pound units are to be regarded separately as standard. The values stated in each system may not be exact equivalents; therefore, each system shall be used independently of the other. Combining values from the two systems may result in non-conformance with the standard.

NOTE 1—The values are stated in inch-pound for inch fasteners and SI metric units for metric fasteners.

1.5 *This standard does not purport to address all of the safety concerns, if any, associated with its use. It is the responsibility of the user of this standard to establish appropriate safety and health practices and determine the applicability of regulatory limitations prior to use.*

2. Referenced Documents

2.1 ASTM Standards:²

- [A394 Specification for Steel Transmission Tower Bolts, Zinc-Coated and Bare](#)
- [E4 Practices for Force Verification of Testing Machines](#)
- [E8/E8M Test Methods for Tension Testing of Metallic Materials](#)
- [E10 Test Method for Brinell Hardness of Metallic Materials](#)
- [E18 Test Methods for Rockwell Hardness of Metallic Materials](#)
- [E83 Practice for Verification and Classification of Extensometer Systems](#)
- [E92 Test Methods for Vickers Hardness and Knoop Hardness of Metallic Materials](#)
- [E384 Test Method for Microindentation Hardness of Materials](#)
- [F436/F436M Specification for Hardened Steel Washers Inch](#)

² For referenced ASTM standards, visit the ASTM website, www.astm.org, or contact ASTM Customer Service at service@astm.org. For *Annual Book of ASTM Standards* volume information, refer to the standard's Document Summary page on the ASTM website.

***A Summary of Changes section appears at the end of this standard**

and Metric Dimensions

F959 Specification for Compressible-Washer-Type Direct Tension Indicators for Use with Structural Fasteners

F1624 Test Method for Measurement of Hydrogen Embrittlement Threshold in Steel by the Incremental Step Loading Technique

F2328 Test Method for Determining Decarburization and Carburization in Hardened and Tempered Threaded Steel Bolts, Screws, Studs, and Nuts

F2328M Test Method for Determining Decarburization and Carburization in Hardened and Tempered Threaded Steel Bolts, Screws, Studs, and Nuts (Metric)

2.2 Military Standard.³

MIL STD 1312, Test 13 and Test 20

3. Test Methods for Externally Threaded Fasteners

3.1 *Product Hardness*—Tests shall be conducted after the removal of any surface oxide, decarburization, plating or other coating. All readings shall be within the hardness values listed in the product specification. The average of all readings on the same part shall be considered as the product hardness. Test results shall conform to the product specification for the lot represented by the test specimens to be considered conforming. Test specimen preparation and hardness tests shall be conducted in accordance with Test Methods E18 for Rockwell tests, Test Method E10 for Brinell tests, Test Method E92 for Vickers tests, or Test Method E384 for Microhardness tests. The method used is at the option of the manufacturer, with regards to the size and grade of the products.

3.1.1 *Routine Test Locations*—For testing the hardness of the finished product, the following test locations can be used:

3.1.1.1 For hex and square head bolts; test shall be conducted on the wrench flats, top of head, unthreaded shank, end of bolt or at the arbitration location.

3.1.1.2 For studs, products without parallel wrench flats and for head styles other than hex and square; tests shall be conducted on the unthreaded shank, end of the bolt or stud or at the arbitration location.

3.1.1.3 Stress relieved products (3.1.1.1 and 3.1.1.2) are measured anywhere on the surface or through the cross section. Refer to the product specification for particular test location or use the arbitration location.

3.1.1.4 The Rockwell Hardness Scale may be used for all product diameters; however, the Brinell hardness is limited to products over 1½-in. or M36.

3.1.2 *Laboratory Inspection*—A minimum of three readings shall be taken on each sample of finished product.

3.1.3 *Arbitration Test Location*—For purposes of arbitration between the purchaser and seller over reported test results, hardness tests shall be conducted at the mid-radius ($r/2$) of a transverse section through the threads taken at a distance of approximately one diameter from the point end of the bolt or one end of the stud. Four readings shall be taken from the point end of the bolt or one end of the stud. Four readings shall be taken approximately 90° to one another on the same plane, if product size permits. Smaller diameter products may also use the opposite parallel surface area of the bolt head end as sectioned above (see Fig. 1). The use of Brinell hardness for arbitration testing is limited to product sizes greater than 2¼-in. or M60.

3.2 *Tension Tests*—It is preferred that bolts and studs be tested full size, and it is customary, when so testing, to specify a minimum ultimate load (or stress) in pounds-force (or pounds-force per square inch.) for inch fasteners and or load in newtons-force or megapascals MPa for metric fasteners. Sections 3.2 – 3.5 apply when testing externally threaded fasteners full size. Section 3.6 shall apply where the individual product specifications permit the use of machined specimens (see Test Methods E8/E8M).

3.2.1 *Proof Load*—The proof-load test consists of stressing the product with a specified load that the product must withstand without measurable permanent set. **Alternative tests**

³ DLA Document Services Building 4/D 700 Robbins Avenue Philadelphia, PA 19111-5094 <http://quicksearch.dla.mil/>

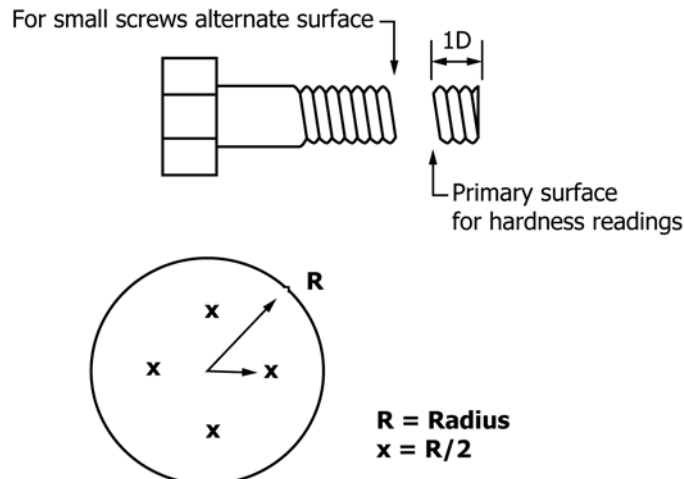

FIG. 1 Hardness Arbitration Test Location

for determining the ability of a fastener to pass the proof-load test are the yield strength test and the uniform hardness test.

Either Method 1 (3.2.3), Method 2 (3.2.4), or Method 3 (3.2.5) may be used, but Method 1 shall be the arbitration method in case of any dispute as to acceptance of the product (see Test Methods E8/E8M).

3.2.2 In both Methods 1 and 2, assemble the product in the fixture of the tension testing machine so that six complete threads (except for heavy hex structural bolts, which shall be based on four threads) are exposed between the grips. This is obtained by freely running the nut or fixture to the thread runout of the specimen and then unscrewing the specimen six full turns. For continuous thread bolts, at least six full threads shall be exposed between the fixture ends; however, for referee purposes, six full threads shall be exposed.

3.2.3 *Method 1, Length Measurement*—To ensure consistent and repetitive length measurements of the fastener, the threaded end and top of the bolt head shall have conical depressions made at the approximate axis or center line of the fastener. In the event of a dispute over test results the test shall be conducted after the removal of all manufacturer or grade markings, surface oxide, decarburization, plating, other coating, or a combination thereof, to achieve a clean, flat surface and the conical depressions shall be created using a lathe or some type of centering fixture. All debris shall be removed from the conical depressions before measuring the part. When fasteners are too long to test in the available equipment the fastener may be cut to 8 inches \pm 0.125 for inch fasteners or a length of 200 mm \pm 3.0 mm for metric fasteners and tested using Method 1. If there is a dispute over results when testing the same part or lot of parts, both full size and cut fastener the cut fastener results shall be used to determine acceptance. The measuring instrument shall have pointed anvils which mate with the center line depressions and be capable of measuring changes in length of 0.0001 in. for inch fasteners and 0.0025 mm for metric fasteners. The instrument accuracy shall be within 0.0001 in. in any 0.001 in. range for inch parts and within 0.0025 mm accuracy within any 0.025 mm range for metric parts. Place the fastener between the measuring anvils. The fastener shall be rotated at least 360 degrees to assure sound seating. At the position where the lowest value is indicated the instrument shall be zeroed or the indicated measurement shall be recorded. If using a bolt extensometer, the bolt with attached extensometer may be assembled into the tension testing machine. If not, mark the fastener so it may be placed as close as possible to the same position for the second reading. Remove and assemble the fastener into the tension testing machine as outlined in 3.4. With a test speed which shall not exceed 0.12 in./min for inch fasteners and 3.0 mm/min for metric fasteners, as determined with a free-running cross head, axially load the fastener to the proof load value specified in the product specification. This load shall be maintained for a period of 10 s before releasing the load. Replace the fastener between the measuring anvils and rotate at least 360 degrees as before. The fastener shall be stopped at the position where the lowest value is indicated. The measurement shall show no permanent elongation. A tolerance of \pm 0.0005 in. for inch fasteners and \pm 0.013 mm for metric

fasteners shall be allowed (for measurement error only) between the measurement made before loading and that made after loading. Variables such as straightness, thread alignment, or measurement error could result in apparent elongation of the product when the specified proof load is initially applied. In such cases, the product may be retested using a 3 % greater load, and shall be considered acceptable if there is no difference in the length measurement after this loading within a 0.0005 in. for inch fasteners and \pm 0.013 mm for metric fasteners, measurement tolerance as outlined.

3.2.4 *Method 2, Yield Strength*—Assemble the product in the testing equipment as outlined in 3.4. As the load is applied, measure and record the total elongation of the product or any part of it that includes the exposed threads to produce a load-elongation diagram. Determine the load or stress at an offset equal to 0.2 % of the length of bolt occupied by six full threads as shown in Fig. 2 (except for heavy hex structural bolts, which shall be based on four threads) by the method described in 3.6.3.1.

3.2.4.1 *Method 2A, Yield Strength for Austenitic Stainless Steel and Non-ferrous Materials*—Assemble the product in the testing equipment as outlined in 3.4. As the load is applied, measure and record the total elongation of the product in order to produce a load elongation diagram. Determine the load or stress at an offset equal to 0.2 % strain based on the length of the bolt between the holders as shown in Fig. 2, which will be subject to elongation under load by using the method described in 3.6.3.1.

3.2.5 *Method 3, Uniform Hardness*—The fasteners shall be tested for hardness as described in 3.1, and in addition, the hardness shall also be determined in the core. The difference between the mid-radius and core hardness shall be not more than 3 points on a Rockwell C Scale; and both readings must be within product specification. This test is valid for fasteners up to and including 1 in. for inch fasteners and M24 diameter for metric fasteners.

3.3 *Bolts or Studs Too Short for Tension Testing*—Product lengths less than those shown in Table 1 for product $\frac{1}{4}$ through $\frac{3}{4}$ in. for inch fasteners and M5 through M20 for metric fasteners in diameter and less than three diameters in length for product above $\frac{3}{4}$ in. and M20 in diameter, or that do not have sufficient threads for proper engagement and still leave the specified number of complete threads exposed between the grips, shall be deemed too short for tension testing, and acceptance shall be based on a hardness test performed in accordance with 3.1. If tests other than product hardness are required, their requirements should be referenced in the product specification. When differences in tensile testing lengths exist between this standard and product standards, the requirements of the product standard shall take precedence. Minimum length in Table 1 indicates the nominal specified length of an inch fastener (that is an A449 Hex Cap Screw size is specified as $\frac{1}{2}$ -13 \times 1 $\frac{1}{8}$ indicates 1 $\frac{1}{8}$ in. is the nominal length) and Table 2 for a metric fastener for size M12 \times 30 indicates the nominal length is 30 mm.

3.4 Axial Tension Testing of Full-Size Products:

3.4.1 Bolts may be tested in a holder with the load axially applied between the head and a nut or suitable fixture (Fig. 2),

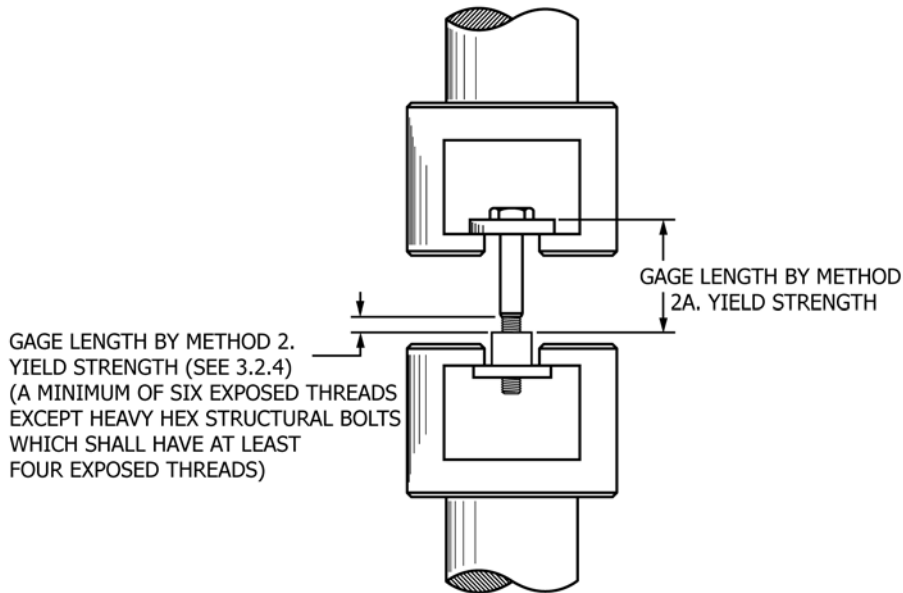

FIG. 2 Tension Testing of Full-Size Bolt (Typical Set-Up)

TABLE 1 Minimum Length of Product Requiring Tension Testing

Nominal Product Size, in.	Minimum Nominal Length, in.
1/4	5/8
5/16	3/4
3/8	7/8
7/16	1
1/2	1 1/8
9/16	1 1/4
5/8	1 1/2
3/4	1 3/4
7/8 and larger	3 dia

TABLE 2 Minimum Length of Product Requiring Tension Testing

Nominal Product Size, mm	Minimum Nominal Length, mm
M5	12
M6	14
M8	20
M10	25
M12	30
M14	35
M16	40
M20	45
Over M20	3 dia

ends. The maximum speed of the free-running cross head shall not exceed 1 in./min for inch fasteners and 25 mm/min for metric fasteners. When reporting the tensile strength of inch product, in pounds-force per square inch, calculate the thread stress area as follows:

$$A_s = 0.7854 [D - (0.9743/n)]^2 \quad (1)$$

where:

- A_s = thread stress area, in.²,
- D = nominal diameter of bolt or stud, in., and
- n = number of threads per inch.

When reporting the tensile strength of metric product, in megapascals MPa calculate the thread stress area as follows:

$$A_s = 0.7854 [D - (0.9382 P)]^2 \quad (2)$$

where:

- A_s = thread stress area, mm²,
- D = nominal diameter of bolt or stud, mm, and
- P = thread pitch, mm.

3.4.3 To meet the requirements of the test described in 3.4.1 and 3.4.2, the product shall support a load prior to fracture not less than the minimum tensile load specified in the product specification for its size, strength, and thread series. In addition, unless otherwise specified, the tensile fracture shall occur in the free threaded length. Fracture in the head or at the junction of the head and shank is prohibited at any load, including those above the minimum requirements.

3.4.3.1 For externally threaded fasteners, if the unthreaded shank diameter is reduced to be equal to or less than the basic thread pitch diameter, the fracture shall occur in the free threaded length or in the unthreaded shank.

3.4.3.2 For screws threaded to the head, fracture that causes failure may extend or spread into the transition section between the head and the thread, or into the head, before separation, provided that it originates in the free threaded length.

either of which shall have sufficient thread engagement to develop the full strength of the product. Assemble the nut or fixture on the product, leaving a minimum of six complete bolt threads exposed between the grips except for heavy hex structural bolts, which shall have four complete threads exposed between the grips.

3.4.2 Studs may be tested by assembling one end in the threaded fixture to the thread runout. For studs having unlike threads, this shall be the end with the finer pitch thread, or with the larger minor diameter. Likewise, assemble the other end of the stud in a threaded fixture, leaving six complete threads exposed between the grips. For continuously threaded studs, at least six complete threads shall be exposed between the fixture

3.4.3.3 For fasteners made of non hardened steel (that is, not quench and tempered) or austenitic stainless steel, the fracture shall occur in the free threaded length or in the unthreaded shank.

3.4.3.4 For fasteners made of austenitic stainless steel, if the test fastener's thread pulls out of the internally threaded test fixture above the minimum specified tensile load, the fastener shall be considered conforming to the tensile strength requirement.

3.5 *Wedge Tension Testing of Full-Size Product*—The wedge tensile strength of a hex or square-head fastener, socket-head cap screw (with the exception of socket button or flat counter-sunk head products) or stud is the tensile load that the product is capable of sustaining when stressed with a wedge under the head. The purpose of this test is to obtain the tensile strength and demonstrate the “head quality” and ductility of the product.

3.5.1 *Wedge Tension Testing of Bolts*—Determine the ultimate load of the bolt as described in 3.4 except place a wedge under the bolt head. When both wedge tension and proof load testing are required by the product specification the bolts that have been the proof load-tested in accordance with Method 1 (3.2.3) or Method 3 (3.2.5) may be used for wedge testing. Fasteners that have been yield strength tested utilizing either Method 2 (3.2.4) or Method 2A (3.2.4.1) shall not be reused for wedge testing. The wedge shall have a minimum hardness of 45 HRC. Additionally, the wedge shall have a minimum thickness of one half the nominal bolt diameter (measured at the thin side of the hole, see Fig. 3). The wedge shall have an included angle as shown in Table 3 and Table 4 for the product type being tested. The hole in the wedge shall have a clearance over the nominal size of the bolt, and its top and bottom edges shall be rounded as specified in Table 5 and Table 6. The minimum outside dimension of the wedge shall be such that during the test no corner loading of the product head (adjacent to the wedge) shall occur (see head orientation in Fig. 3). The bolt shall be tension tested to fracture. To meet the requirements of this test, the bolt shall support a load prior to fracture not less than the minimum tensile load specified in the product specification for its size, strength, and thread series. In addition, unless otherwise specified, the tensile fracture shall occur in the free thread length. Fracture in the head or at the junction of the head and shank is prohibited at any load, including those above the minimum requirements.

NOTE 2—Fasteners that have been manufactured/in-stock or on order prior to the approval of Test Methods F606/F606M–16 that utilized the same fastener for both yield strength and wedge tensile testing are acceptable and may be supplied/used as-is without additional testing until existing stock has been depleted. Fasteners that are placed on order and manufactured after the issuance of Test Methods F606/F606M–16 that are yield strength and wedge tensile tested shall follow the revised requirement in 3.5.1.

3.5.1.1 For externally threaded fasteners, if the unthreaded shank diameter is reduced to be equal to or less than the basic thread pitch diameter, the fracture shall occur in the free threaded length or in the unthreaded shank.

3.5.1.2 For screws threaded to the head, fracture that causes failure may extend or spread into the transition section between

the head and the thread, or into the head, before separation, provided that it originates in the free threaded length.

3.5.1.3 For fasteners made of non hardened steel (that is, not quench and tempered) or austenitic stainless steel, the fracture shall occur in the free threaded length or in the unthreaded shank.

3.5.1.4 For fasteners made of austenitic stainless steel, if the test fastener's thread pulls out of the internally threaded test fixture above the minimum specified tensile load, the fastener shall be considered conforming to the wedge tensile strength requirement.

NOTE 3—Fracture at the junction of the head and shank is prohibited at any load, including those above the minimum requirements.

3.5.2 *Wedge Tension Testing of Studs*—When both wedge tension and proof load testing are required by the product specifications, assemble one end of the same stud previously used for proof load testing in a threaded fixture to the thread runout. For studs having unlike threads, this shall be the end with the finer pitch thread or with the larger minor diameter. Assemble the other end of the stud in a threaded wedge to the runout and then unscrew six full turns, thus leaving six complete threads exposed between the grips, as illustrated in Fig. 4. For continuous thread studs, at least six complete threads shall be exposed between the fixture ends. The angle of the wedge for the stud size and grade or property class shall be as specified in Table 3 and Table 4. Assemble the stud in the testing machine and tension test to fracture, as described in 3.4. The minimum hardness of the threaded wedge shall be 45 HRC. The length of the threaded section of the wedge shall be equal to at least the diameter of the stud. To facilitate removal of the broken stud, the threaded wedge may be counterbored on the faces as shown in Fig. 4. The thickness of the wedge at the thin side of the hole shall equal the diameter of the stud plus the depth of counterbore. The thread in the wedge shall have Class 3B tolerances for inch parts and a 5H tolerance for metric parts, except when testing studs having an interference fit thread, in which case the wedge shall be threaded to provide a finger-tight fit. The supporting fixture, as shown in Fig. 4, shall have a hole clearance over the nominal size of the stud, and shall have its top and bottom edges rounded or chamfered to the same limits specified for the hardened wedge washers in Table 5 and Table 6. To meet the requirements of this test, the stud shall support a load prior to fracture not less than the minimum tensile strength specified in the product specification for its size, grade, and thread series. When tensile testing externally threaded fasteners made of austenitic stainless steel and the test fastener's thread pulls out of the internally threaded test fixture after the minimum tensile strength requirement has been reached, the fasteners shall be considered conforming to the tensile strength requirement.

NOTE 4—Dimensional tolerances for all test fixtures used in this test method, unless otherwise noted, shall conform to standard machining practices.

3.6 *Tension Testing of Machined Test Specimens:*

3.6.1 Where bolts and studs cannot be tested full size, conduct tests using test specimens machined from the bolt or stud (see Test Methods E8/E8M).

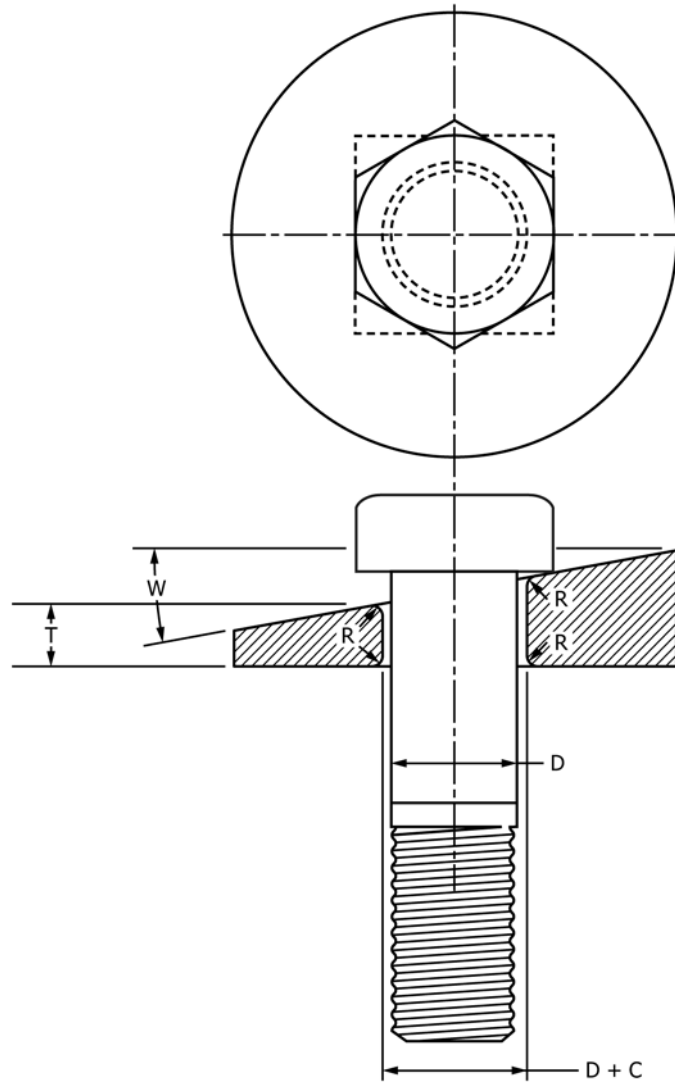

c = clearance of hole
 D = diameter of bolt or screw
 R = radius or chamfer
 T = reference thickness of wedge at thin side of hole equals one half diameter of bolt or screw
 W = wedge angle (see Table 3)

FIG. 3 Wedge Test Details—Bolts

TABLE 3 Tension Test Wedge Angles for Inch Bolts and Screws

NOTE 1—For use with hardened and tempered steel and alloy steel standard products. For non-ferrous and special products, see the related product specification. Unless otherwise specified, Table 3 shall apply.

Nominal Product Size, in.	Degrees	
	Bolts ^A	Studs and Flange Bolts
¼ – 1	10	6
Over 1	6	4

^A Heat-treated bolts that are threaded one diameter or closer to the underside of the head, shall use a wedge angle of 6° for sizes ¼ through ¾ in. and 4° for sizes over ¾ in.

TABLE 4 Tension Test Wedge Angles for Metric Bolts and Screws

NOTE 1—For use with hardened and tempered steel and alloy steel standard products. For non-ferrous and special products, see the related product specification.

Nominal Product Size, mm.	Degrees	
	Bolts ^A	Studs and Flange Bolts
M5–M24	10	6
Over M24	6	4

^A Heat-treated bolts that are threaded one diameter or closer to the underside of the head, shall use a wedge angle of 6° for sizes M5 through M20 and 4° for sizes over M20.

3.6.1.1 Bolts and studs ⅙ in. and smaller may be machined concentric with the axis of the bolt or stud for inch fasteners

and M14 for metric fasteners. The specimen shall have a turned

TABLE 5 Tensile Test Wedge Hole Clearance—Details for Inch Bolts and Screws

NOTE 1—Fracture at the junction of the head and shank is prohibited at any load, including those above the minimum requirements.

Nominal Product Size, in.	Nominal Clearance in Hole, in.	Nominal Radius on Corners of Hole, in.
¼ – ½	0.030	0.030
⅜ – ¾	0.050	0.060
⅞ – 1	0.060	0.060
1⅛ – 1¼	0.060	0.125
1⅜ – 1½	0.094	0.125
1¾ – 2	0.094	0.225
2¼ – 3	0.125	0.256

TABLE 6 Tensile Test Wedge Hole Clearance—Details for Metric Bolts and Screws

NOTE 1—Fracture at the junction of the head and shank is prohibited at any load, including those above the minimum requirements.

Nominal Product Size, mm.	Nominal Clearance in Hole, mm	Nominal Radius on Corners of Hole, mm
M5 and M6	0.50	0.70
Over M6–M12	0.80	0.80
Over M12–M20	1.60	1.30
Over M20–M36	3.20	1.60
Over M36	3.20	3.20

section as large as feasible and shall have a gage length four times the diameter of the specimen. See Fig. 5, Fig. 6.

3.6.1.2 Bolts and studs ⅝ in. in diameter through 1¼ in. for inch fasteners and M16 through M30 for metric fasteners may have their shanks machined concentric with the axis of the bolt or stud, leaving the bolt head and threaded section intact as shown in Fig. 5 and Fig. 6, however heat treated bolts in these size ranges must not be reduced by more than 25% of their original diameter. Alternatively, bolts and studs ⅝ in. in diameter through 1¼ in. for inch fasteners and M16 through M30 for metric fasteners may have their shanks machined to a test specimen with the axis of the specimen located midway between the axis and outside surface of the bolt or stud as shown in Fig. 7. Bolts of a small cross section that will not permit taking test specimens as shown in Fig. 5 or Fig. 6 for inch and metric fasteners respectively, shall have a turned section as large as feasible and concentric with the axis of the bolt or stud. The gage length for measuring the elongation shall be four times the diameter of the specimen. Fig. 5 and Fig. 6 illustrate an example of these small-size specimens. For arbitration purposes, machined test specimens for bolts and studs ⅝ in. through 1¼ in. for inch fasteners and M16 through M30 for metric fasteners shall be machined with the axis of the specimen located midway between the center and outside surface shown in Fig. 7.

3.6.1.3 Bolts and studs 1⅜ in. or M33 and larger may have their shanks machined to test specimen with the axis of the specimen located midway between the center and outside surface of the bolt or stud as shown in Fig. 7 to sizes indicated in Fig. 5 and Fig. 6 for inch and metric fasteners respectively.

3.6.1.4 Machined test specimens shall exhibit tensile strength, yield strength (or yield point), elongation, and reduction of area equal to or greater than the values of these

properties specified for the product size in the applicable product specification when tested in accordance with this section.

3.6.2 Determination of Tensile Properties:

3.6.2.1 *Yield Point*—Yield point is the first stress in a material, less than the maximum obtainable stress, at which an increase in strain occurs without an increase in stress. Yield point is intended for application only for materials that may exhibit the unique characteristic of showing an increase in strain without an increase in stress. The stress-strain diagram is characterized by a sharp knee or discontinuity. Determine yield point by one of the following methods:

3.6.2.2 *Drop of the Beam or Halt of the Pointer Method*—In this method apply an increasing load to the specimen at a uniform rate. When a lever and poise machine is used, keep the beam in balance by running out the poise at approximately a steady rate. When the yield point of the material is reached, the increase of the load will stop, but run the poise a trifle beyond the balance position, and the beam of the machine will drop for a brief but appreciable interval of time. When a machine equipped with a load-indicating dial is used, there is a halt or hesitation of the load-indicating pointer corresponding to the drop of the beam. Note the load at the “drop of the beam” or the “halt of the pointer” and record the corresponding stress as the yield point.

3.6.2.3 *Autographic Diagram Method*—When a sharp-kneed stress-strain diagram is obtained by an autographic recording device, take the stress corresponding to the top of the knee (Fig. 8), or the stress at which the curve drops as the yield point (Fig. 9).

3.6.2.4 *Total Extension Under Load Method*—When testing material for yield point and the test specimens may not exhibit a well-defined disproportionate deformation that characterizes a yield point as measured by the drop of the beam, halt of the pointer, or autographic diagram methods described in 3.6.2.2 and 3.6.2.3, a value equivalent to the yield point in its practical significance may be determined by the following method and may be recorded as yield point: Attach a Class C or better extensometer (Note 5 and Note 6) to the specimen. When the load producing a specified extension (Note 7) is reached, record the stress corresponding to the load as the yield point, and remove the extensometer (Fig. 10).

NOTE 5—Automatic devices are available that determine the load at the specified total extension without plotting a stress-strain curve. Such devices may be used if their accuracy has been demonstrated. Multiplying calipers and other such devices are acceptable for use provided their accuracy has been demonstrated as equivalent to a Class C extensometer.

NOTE 6—Reference should be made to Practice E83.

NOTE 7—For steel inch fasteners with a specified yield point not over 80 000 psi, an appropriate value is 0.005 in./in. of gage length. For values above 80 000 psi, this test method is not valid unless the limiting total extension is increased. For steel metric fasteners with a specified yield point not over 550 MPa, an appropriate value is 0.13 mm/mm of gage length. For values above 550 MPa, this test method is not valid unless the limiting total extension is increased.

3.6.3 *Yield Strength*—Yield strength is the stress at which a material exhibits a specified limiting deviation from the proportionality of stress to strain. The deviation is expressed in terms of strain, percent offset, total extension under load, etc. Determine yield strength by one of the following methods:

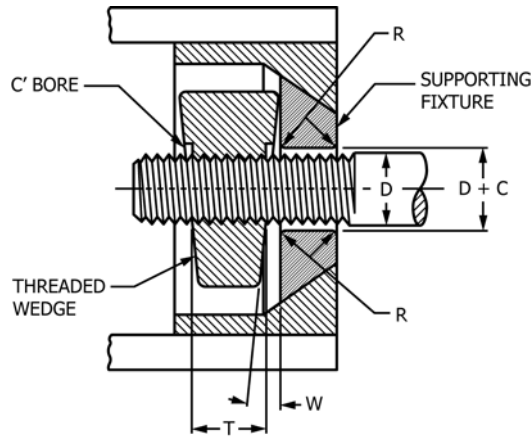

C = clearance of hole,
 D = diameter of stud,
 R = radius or chamfer,
 T = E plus depth of counterbore,
 W = wedge angle,
 E = length of threaded section of wedge = D

FIG. 4 Wedge Test Details—Studs

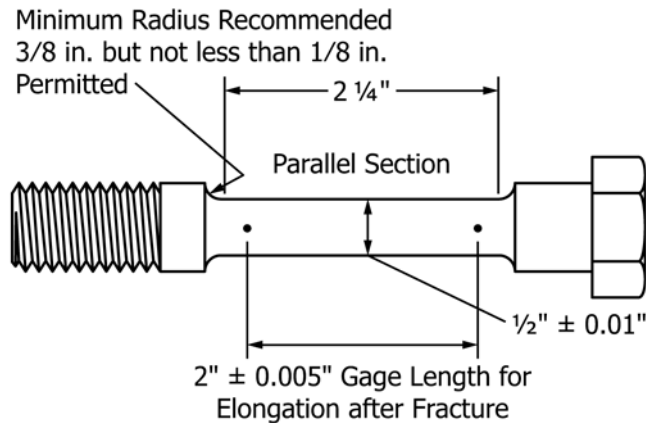

FIG. 5 Tension Test Specimen for Bolt with Turned-Down Shank for Inch Bolts

3.6.3.1 *Offset Method*—To determine the yield strength by the “offset method,” it is necessary to secure data (autographic or numerical) from which a stress-strain diagram may be drawn. Then on the stress-strain diagram (Fig. 8) lay off om equal to the specified value of the offset, draw mn parallel to oA , and thus locate r . The yield strength load R is the load corresponding to the highest point of the stress-strain curve before or at the intersection of mn with r . In reporting values of yield strength obtained by this method, the specified value of “offset” used should be stated in parentheses after the term yield strength. For inch fasteners:

$$\text{Yield strength (0.2\% offset)} = 52\,000 \text{ psi} \quad (3)$$

For metric fasteners:

$$\text{Yield strength (0.2\% offset)} = 360 \text{ MPa} \quad (4)$$

In using this method, a minimum extensometer magnification of 250 to 1 is required. A Class B1 extensometer meets this requirement (see Note 6). See also Note 5 for automatic devices.

3.6.3.2 *Extension Under Load Method*—For tests to determine the acceptance or rejection of material whose stress-strain characteristics are well known from previous tests of similar material in which stress-strain diagrams were plotted, the total strain corresponding to the stress at which the specified offset (see Note 8) occurs will be known within satisfactory limits. The stress on the specimen, when this total strain is reached, is the value of the yield strength. The total strain can be obtained satisfactorily by use of a Class B1 extensometer (Note 5 and Note 6).

NOTE 8—The appropriate magnitude of the extension under load will obviously vary with the strength range of the particular material under test. In general, the value of extension under load applicable to any material strength level may be determined from the sum of the proportional strain and the plastic strain expected at the specified yield strength. The following equation is used:

$$\text{Extension under load, in./in. of gage length for inch fasteners and mm/mm of gage length for metric fasteners} = (YS/E) = r$$

where:

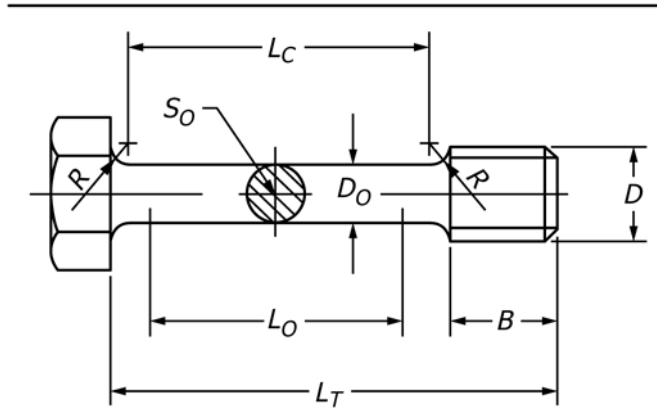

D = nominal thread diameter,
 D_O = diameter of test piece ($D_O < \text{minor diameter of thread}$),
 B = length of thread ($B \geq D$),
 $L_O = 5D_O$ or $(5.65 \sqrt{S_O})$,
 L_C = length of straight portion ($L_O + D_O$),
 L_T = total length of test piece ($L_C + 2R + B$),
 L_U = length after fracture,
 S_O = cross-sectional area, and
 R = fillet radius ($R \geq 4\text{mm}$)

FIG. 6 Tension Specimens with Turned-down Shank for Metric Bolts

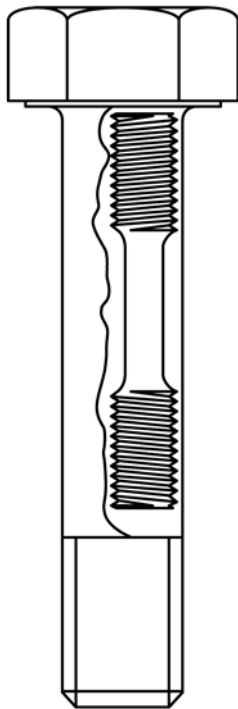

FIG. 7 Location of Standard Round 2-in. Gage Length Tension Test Specimen When Turned from Large Size Bolt

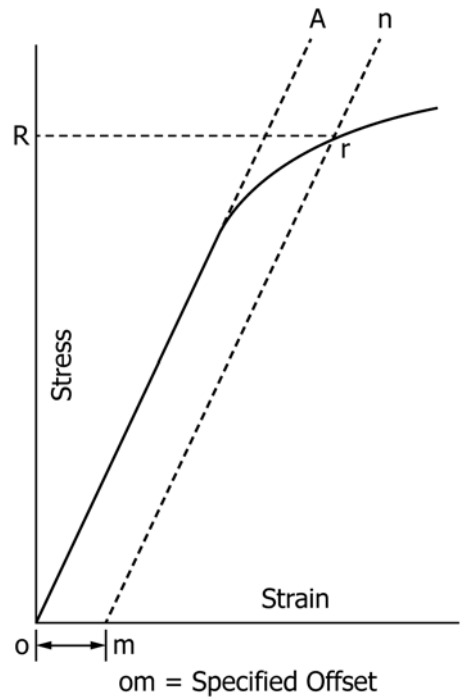

FIG. 8 Stress-Strain Diagram for Determination of Yield Strength by the Offset Method

YS = specified yield strength, psi for inch fasteners and MPa for metric fasteners,
 E = modulus of elasticity, psi for inch fasteners and MPa for metric fasteners, and
 r = limiting plastic strain, in./in for inch fasteners and mm/mm for metric fasteners.

3.6.4 *Tensile Strength*—Calculate the tensile strength by dividing the maximum load the specimen sustains during a tension test by the original cross-sectional area of the specimen.

3.6.5 *Elongation:*

3.6.5.1 Fit the ends of the fractured specimen together carefully and measure the distance between the gage marks to

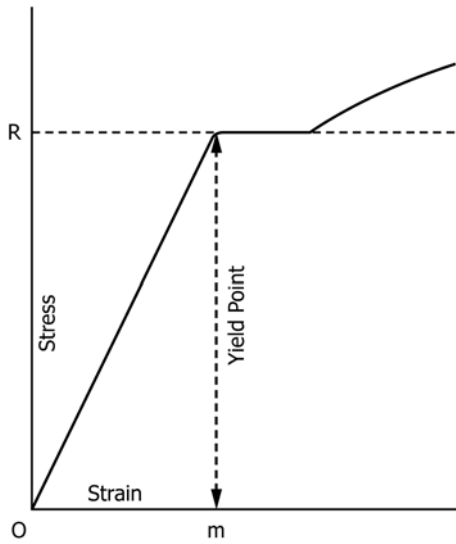

FIG. 9 Stress-Strain Diagram Showing Yield Point Corresponding with Top of Knee

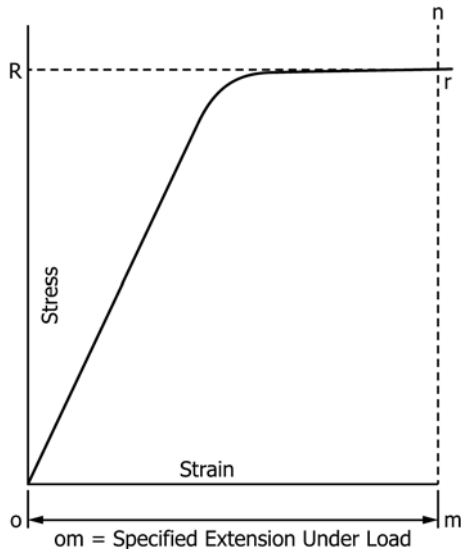

FIG. 10 Stress-Strain Diagram Showing Yield Point or Yield Strength by Extension Under Load Method

the nearest 0.01 in. for gage lengths through 2 in. or 0.25 mm through 50 mm gauge length. Measure to the nearest 0.5 % of

longer gage lengths. The elongation is the increase in length of the gage length, expressed as a percentage of the original gage length. In reporting elongation values, give both the percentage increase and the original gage length.

3.6.5.2 If any part of the fracture takes place outside of the middle half of the gage length or in a punched or scribed mark within the reduced section, the elongation value obtained may not be representative of the material. If the elongation so measured meets the minimum requirements specified, no further testing is indicated, but if the elongation is less than the minimum requirements, discard the test and retest.

3.6.6 *Reduction of Area*—Fit the ends of the fractured specimen together and measure the mean diameter or the width and thickness at the smallest cross section to the same accuracy as the original dimensions. The difference between the area thus found and the area of the original cross section expressed as a percentage of the original area, is the reduction of area.

3.7 *Total Extension at Fracture Test:*

3.7.1 The extension at fracture (A_L) test shall be carried out on stainless steel and nonferrous products (bolts, screws, and studs) in the finished condition, with lengths equal to or in excess of those minimums listed in Table 1 and Table 2.

3.7.2 The products to be tested shall be measured for total length (L_1) as described in 3.7.2.1 and shown in Fig. 11.

3.7.2.1 Mark both ends of the bolt, screw, or stud using a permanent marking substance such as bluing so that measuring reference points for determining total length L_1 and L_2 are established. Using an open-end caliper and steel rule or other device capable of measuring to within 0.010 in., or 0.25 mm, determine the total length of the product as shown in Fig. 11.

3.7.3 The product under test shall be screwed into the threaded adapter to a depth of one diameter (see Fig. 2) and load applied axially until the product fractures. The maximum speed of the free-running cross head shall not exceed 1 in./min for inch fasteners and 25 mm/min for metric fasteners.

3.7.4 After the product has been fractured in accordance with 3.7.3, the two broken pieces shall be fitted closely together and the overall length (L_2) measured (see 3.7.2.1 and Fig. 11). The total extension at fracture shall then be calculated as follows:

$$A_L = L_2 - L_1$$

3.7.5 The value obtained shall equal or exceed the minimum values shown in the applicable specification for the product and material type.

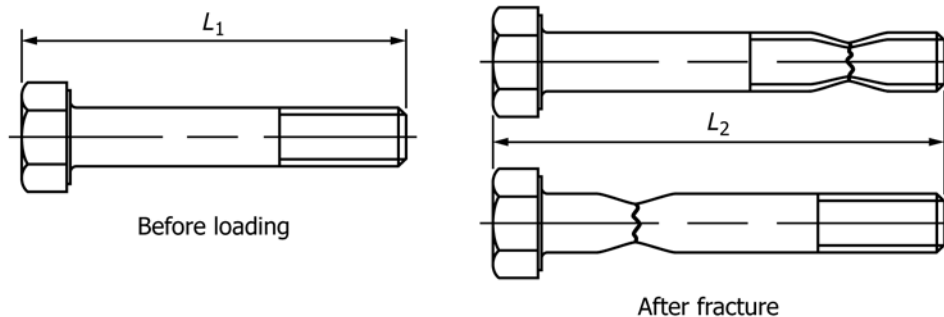

FIG. 11 Determination of Total Extension at Fracture (A_L) (only Screw Product Shown)

3.8 *Single Shear Test*—(Note 9) This test is intended to determine the ability of a fastener to withstand a predetermined load when applied transversely to the axis of the fastener. Shear is defined as an action or stress caused by applied forces that causes two adjacent parts of a body to slide on each other to cause separation. Shear tests may be conducted in either tension-type or compression-type single shear fixture.

3.8.1 The specimen shall be tested using hardened steel plates of sufficient thickness to preclude bearing failure. Holes in the shear plates shall be $\frac{1}{16}$ in. for inch fasteners and 1.5 mm for metric fasteners. The holes shall be chamfered 0.010 in. or 0.25 mm to relieve sharp edges. Shear plates shall be prevented from separating by means of a suitable jig or by using a nut on the test bolt tightened finger tight.

3.8.2 The test specimen, when assembled in the shear jig, shall be mounted in a tensile-testing machine capable of applying load at a controllable rate. The grips shall be self-aligning and care shall be taken when mounting the specimen to assure that the load will be transmitted in a straight line transversely through the test bolt. Load shall be applied and continued until fracture of the bolt. Speed of testing as determined with a free-running cross head shall not be less than $\frac{1}{4}$ in./min or 6.0 mm/min nor greater than $\frac{1}{2}$ in./min or 12.0 mm/min.

3.8.3 The maximum load applied to the specimen, coincident with or prior to bolt fracture shall be recorded as the shear strength of the bolt. At the discretion of the testing activity, tests need not be continued to destruction provided that the specimen supports, without evidence of bolt fracture, the minimum load specified.

3.8.4 A typical test fixture for tension shear testing is shown in Fig. 12.

NOTE 9—This single-shear test is primarily used for testing Specification A394 tower bolts which range in size from $\frac{1}{2}$ through 1 in. diameter. For general use, the shear test practices and fixturing found in MIL STD 1312 Test 13 is used for double shear and Test 20 may be used for single shear.

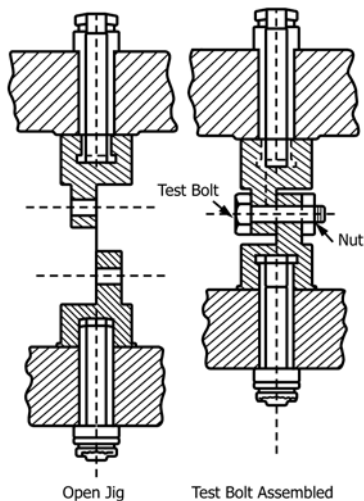

FIG. 12 Typical Single Shear Fixture (Tension Type)

4. Test Methods for Internally Threaded Fasteners

4.1 *Product Hardness*—For routine inspection of both heat-treated and nonheat-treated nuts, hardness shall be determined on the bearing face or wrench flats after removal of any oxide, decarburization, plating, or other coating material. Rockwell or Brinell hardness shall be used at the option of the manufacturer, taking into account the size and grade or property class of the product.

4.1.1 The preparation of test specimens and the performance of hardness tests for Rockwell and Brinell testing shall be in conformance with the requirements of Test Methods E18 and E10, respectively.

4.1.2 Readings when taken on the bearing face shall be halfway between the major diameter of the thread and one corner. The reported hardness shall be the average of two hardness readings located 180° apart. The readings when taken on the wrench flats shall be one third of the distance from a corner to the center of the wrench face. The reported hardness shall be the average of two readings located from opposite corners.

4.1.3 For the purpose of arbitration or for nuts too large for full size testing, where hardness alone shall determine acceptance (see 4.1.4), the following shall apply.

4.1.3.1 Sample nuts shall be sectioned laterally at approximately one half ($\frac{1}{2}$) of the nut height. Such samples need not be threaded, but shall be part of the manufacturing lot that was formed (in the case of heat-treated nuts, formed and heat-treated) with the product to be shipped. The preparation of the sample shall be in accordance with 4.1.1 above. All readings shall be conducted on a Rockwell Hardness testing machine. For standard hex, heavy hex and square nuts, the half of the nut not to be tested may be discarded. For special nut configurations both sections shall be identified and made available to the purchaser, if specified on the purchase order or inquiry.

4.1.3.2 *Nonheat-Treated Nuts* (See Fig. 13)—Two readings shall be taken 180° apart at the core (halfway between the major diameter if threaded, or blank hole if not threaded) and a corner of the nut. The reported hardness shall be the average of the two readings, and in addition both readings shall be within the hardness values listed in the product specification.

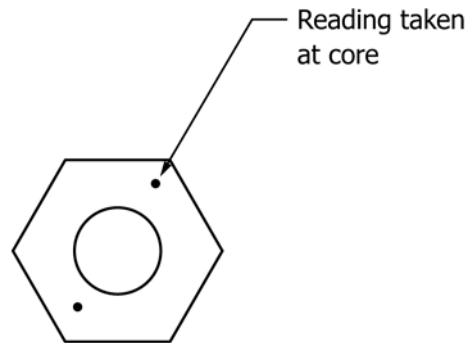

FIG. 13 Nonheat-Treated Nut

4.1.3.3 *Heat-Treated Nuts* (See Fig. 14)—Two sets of three readings 180° apart shall be taken. The three readings shall be taken across the section of the nut at the following positions:

Position 1—As close to the major diameter, as possible, if threaded, or hole side wall if the nut is blank, but no closer than 2½ times the indent diameter.

Position 2—At the core (halfway between the major diameter, if threaded, or hole side wall, if blank) and a corner of the nut.

Position 3—As close to the corner of the nut as possible, but no closer than 2½ times the indent diameter.

4.1.3.4 The reported hardness shall be the average of all six readings. In addition all readings shall be within hardness values listed in the product specification.

4.1.4 Nuts exhibiting a proofload in excess of 160 000 lb for inch nuts or 700 kN for metric nuts may be considered, at the option of the manufacturer, as too large for full-size testing. Full-size testing is recommended whenever possible.

4.1.5 For nuts on which hardness and proof load tests are performed, acceptance based on proof load requirements shall take precedence in the event of controversy with hardness tests.

4.2 *Proof Load Test*—Assemble the nut to be tested on a hardened threaded mandrel (4.2.2) or a test bolt (4.2.1) as illustrated in Fig. 15(a) Tension Method or Fig. 15(b) Compression Method. The hardened test mandrel and the tension method shown in Fig. 15(a) shall be mandatory as a referee if arbitration is necessary. Apply the specified proof load to the nut. The nut shall resist this load without stripping or rupture, and shall be removable from the test bolt or mandrel by the fingers after the load is released. Occasionally it may be necessary to use a manual wrench or other means to start the nut in motion. Use of such means is permissible, provided the nut is removable by the fingers following the initial loosening of not more than one-half turn of the nut. If the threads of the mandrel or test bolt are damaged during the test, discard the test.

4.2.1 The test bolt shall have threads appropriate to the standard specified for the nut being tested and shall have a yield strength in excess of the specified proof load of the nut being tested.

4.2.2 Inch mandrels shall have a hardness of 45 HRC minimum and shall have threads conforming to Class 3A except that the maximum major diameter shall be the minimum major diameter plus 0.002 in. or 0.25 times the major diameter tolerance (whichever is greater) of Class 3A threads.

Metric mandrels shall have a hardness of 45 HRC minimum; the mandrel shall have threads conforming to Class 4h6h except that the maximum major diameter shall be the minimum

major diameter plus 0.05 mm or 0.25 times the major diameter tolerance (whichever is greater) for Class 4h6h.

4.2.3 The proof load shall be determined at a free running cross head speed not exceeding 1.0 in/minute for inch nuts and 25 mm/min for metric nuts and shall be held at load for 10 seconds minimum.

4.3 *Cone Proof Load Test*—Perform this test using a conical washer and threaded mandrel (as illustrated in Fig. 16) to determine the influence of surface discontinuities (that is, forging cracks and seams) on the load-carrying ability of hardened steel nuts through 1½ in., or M36 in diameter by introducing a simultaneous dilation and stripping action of the nut. The mandrel shall conform to the requirements of 4.2.2. The conical washer shall have a hardness of 57 HRC minimum and a hole diameter equivalent to the nominal diameter of the mandrel +0.002, -0.000 in for inch fasteners and + 0.05, -0.0 mm for metric fasteners. The contact point of the cone shall be sharp for nut sizes ½ in. or M12 and less. For sizes over ½ in. or M12, the point shall be flat and 0.014 ± 0.016 in. in width for inch fasteners and 0.35 to 0.41 mm for metric fasteners. Assemble the nut and the conical washer on the mandrel, and apply the cone proof load for the nut against the nut. The speed of testing as determined with a free-running cross head shall be a maximum of 0.12 in./min. for inch fasteners and 3.0 mm/min for metric fasteners. Apply the proof load for 10 s. Compute the cone proof load of a nut as follows:

For inch products:

$$CPL = (1 - 0.30D) \times f \times A_s$$

where:

CPL = cone proof load, lb,
D = nominal diameter of nut, in.,
f = specified proof stress of nut, psi,
A_s = tensile stress area of nut, in.²,
 = 0.7854 [*D* - (0.9743/*n*)]², and
n = threads per inch.

For metric products:

$$CPL = (1 - 0.012D) \times f \times A_s \times 0.001$$

where:

CPL = cone proof load, kN,
D = nominal diameter of nut, mm,
f = specified proof stress of nut, MPa,
A_s = tensile stress area of nut, mm², 0.7854 [*D* - (0.9382/*P*)]², and
P = thread pitch, mm.

To meet the requirements of the cone proof load test, the nut shall support its specified cone proof load without stripping or rupture.

5. Test Methods for Washers and Direct Tension Indicators

5.1 General Requirements:

5.1.1 All tests shall be conducted on a Rockwell hardness tester.

5.1.2 Use of a ¼ in. 6.3 mm or smaller spot anvil shall be used for hardness testing of washers and direct tension indicators

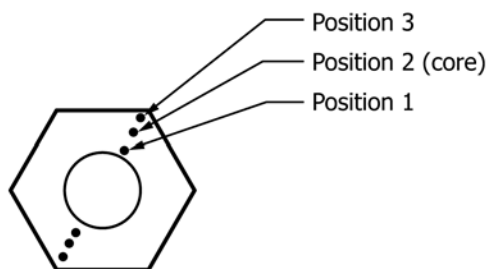

FIG. 14 Heat-Treated Nut

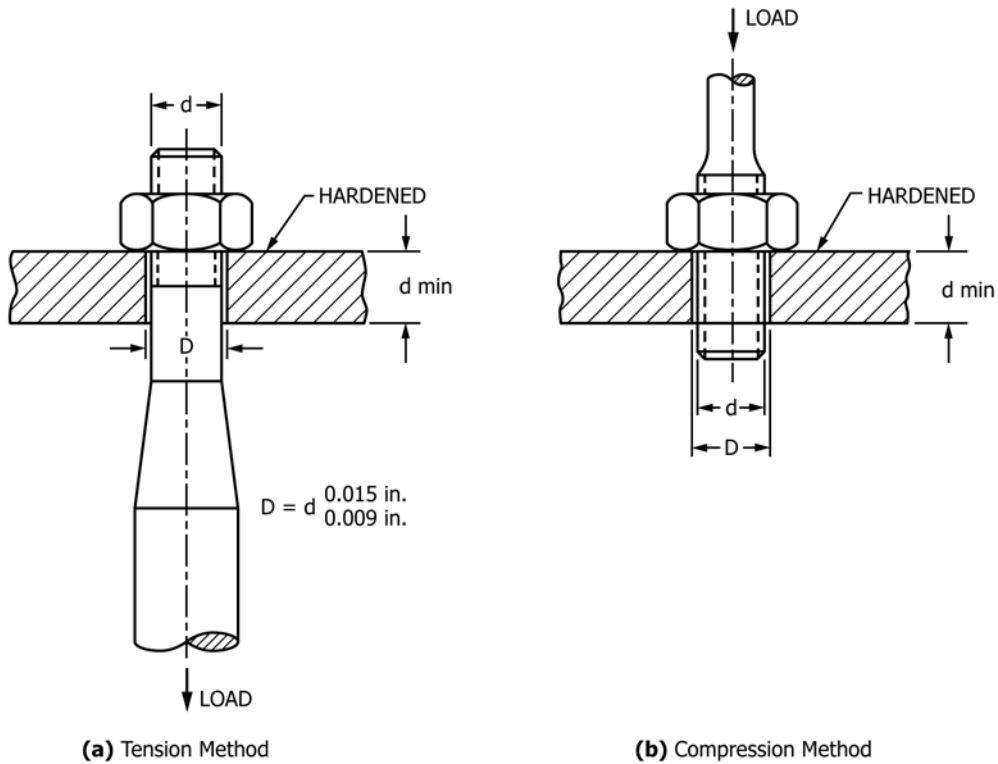

FIG. 15 Proof Load Testing—Nuts

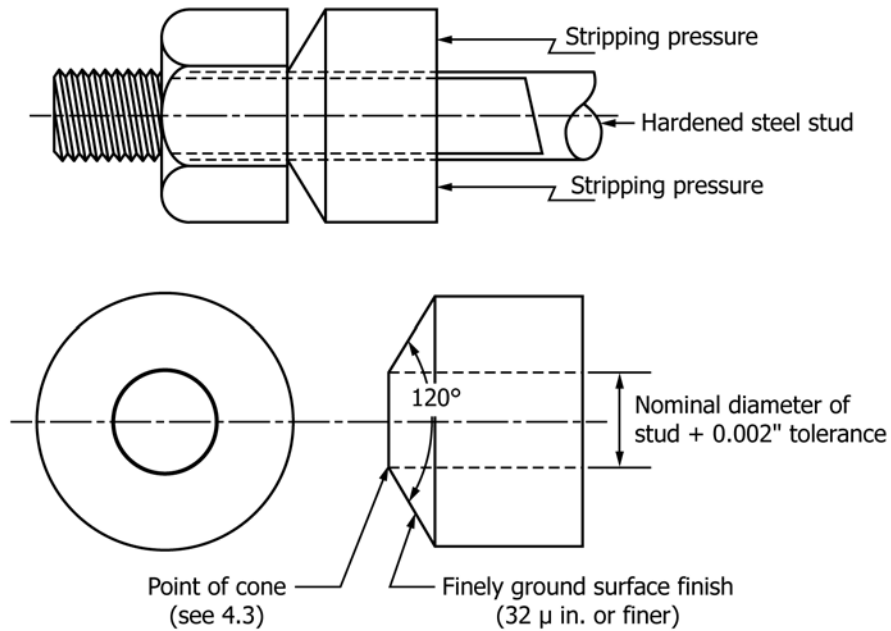

FIG. 16 Cone-Proof Test

5.1.3 Readings are not to be taken on or near product markings.

5.1.4 Preparation of test specimens and the performance of hardness tests shall be performed in accordance with Test Methods E18.

5.1.5 For arbitration purposes, a minimum of two readings 180° apart on at least one face shall be taken (see Fig. 17).

5.1.6 All readings shall be within the hardness values listed in the product specification, and the average of all readings shall be considered as the hardness of the product.

5.1.7 An initial reading may be used to establish that the hardness testing equipment is properly set up and that the correct scale is being used. Such readings are not used to determine conformance.

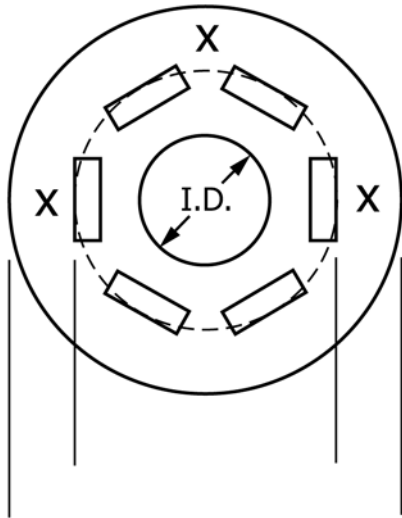

FIG. 17 Typical Hardness Reading Locations

5.2 Through Hardened Washers:

5.2.1 *Surface Hardness*—Tests shall be conducted after the removal of any surface oxide, decarburization, plating or other coatings. Take hardness readings on a smooth flat portion of the washer, prepared by light grinding or polishing as necessary.

5.2.2 *Core Hardness*—Take hardness readings on a smooth flat portion of the washer, prepared by light grinding or polishing such that readings are taken at a minimum depth of 0.015 in. for inch washers and 0.38 mm for metric washers from the original surface.

5.3 Carburized Washers:

5.3.1 *Surface Hardness*—Take hardness readings on a smooth flat portion of the washer, using a method which prevents penetration into the core material.

5.3.2 *Core Hardness*—Take hardness readings on a smooth flat portion of the washer, prepared by light grinding or polishing such that readings are taken at a depth greater than the depth of case.

5.3.3 *Depth of Case*—Measurements of case depth shall be taken at a cross section through the rim of the washer, having been ground and etched to define the case area.

5.4 Stainless Steel and Nonferrous Washers:

5.4.1 *Surface Hardness*—Take hardness readings on a smooth flat portion of the washer.

5.4.2 *Core Hardness*—Take hardness readings on a smooth flat portion of the washer, prepared by light grinding or polishing such that readings are taken at a minimum depth of 0.015 in. for inch washers and 0.38 mm for metric washers from the original surface.

5.5 Direct Tension Indicators (DTI):

5.5.1 *Surface Hardness*—Take hardness readings on a smooth flat portion of the DTI, at a point approximately midway between the protrusion (top side) or pocket (bottom side) and the outside diameter. Prepare the DTI by light grinding or polishing as necessary.

5.5.2 *Core Hardness*—Take hardness readings on a smooth flat portion of the DTI, at a point approximately midway between the protrusion (top side) or pocket (bottom side) and

the outside diameter. Prepare the DTI by light grinding or polishing such that readings are taken at a minimum depth of 0.015 in. for inch DTIs and 0.38 mm for metric DTIs from the original surface.

5.6 Test Method for Measuring Compression Load for Direct Tension Indicators (DTIs):

5.6.1 Testing Apparatus:

5.6.1.1 Test the direct tension indicators in an apparatus described herein that is capable of determining their performance characteristics with sufficient accuracy.

NOTE 10—Because of acceptable variations in bolt dimensions and coating characteristics, bolts cannot be used as a means of gaging the DTIs measured minimum and maximum performance.

5.6.1.2 Testing apparatus shall include a compression loading system, top and bottom bearing blocks, and support blocks that allow each direct tension indicator to be calibrated using a direct reading gage.

5.6.1.3 The testing apparatus shall conform to the requirements of Practices E4. The loads used in determining compressive loads shall be within the verified loading range of the testing machine in accordance with Practices E4.

5.6.1.4 The direct reading gage of the testing apparatus shall be capable of measuring the gap variation to within 0.0005 in for inch DTIs and 0.0125 mm for metric DTIs.

NOTE 11—Because of acceptable variations in bolt dimensions and coating characteristics, bolts cannot be used as a means of gaging the direct tension indicator measured minimum and maximum performance.

5.6.2 Compression Loading System:

NOTE 12—See Specification F959, Table 3 for acceptable range of compression loads.

5.6.2.1 The compression loading system shall transmit a compressive load axially from the testing apparatus to the direct tension indicator. The bottom bearing block of the loading system must be able to accept the cylindrical protrusions of the direct tension indicator support blocks.

5.6.2.2 Maintain the compression loading system in good operating condition and use only in the proper loading range.

5.6.3 Support Blocks:

5.6.3.1 Support blocks shall be grooved on one side so that the direct reading gage can be zeroed without compressing the direct tension indicator protrusions (see Fig. 18). Thus, the exact thickness of the direct tension indicator being tested is taken into account, and the flat surface of the side of the direct tension indicator having protrusions is made to relate exactly to the zero point of the gage that shall react on the center of the direct tension indicator support block.

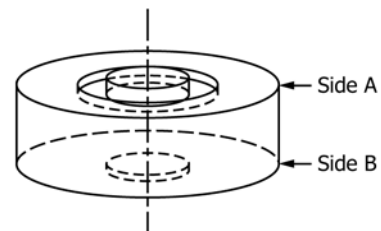

FIG. 18 Support Block

5.6.3.2 Support blocks shall have a minimum Rockwell hardness of 50 HRC.

5.6.3.3 Support blocks shall conform to the following dimensional requirements as depicted in Fig. 19 and Fig. 20.

5.6.4 Bearing Blocks:

5.6.4.1 The upper bearing block shall have a minimum diameter of 3 in 76.2 mm.

5.6.4.2 Bearing blocks shall have a minimum Rockwell hardness of 50 HRC.

5.6.4.3 The upper and bottom bearing block surfaces shall be parallel to within 0.0005 in. 0.0125 mm across the width of the support block.

5.6.5 Calibration:

5.6.5.1 Calibrate the testing apparatus and its direct reading gage at least once per year.

5.6.5.2 Retain the calibrated test data.

5.6.6 Test Procedure:

5.6.6.1 Select the support block corresponding to the size and type of direct tension indicator to be tested.

5.6.6.2 The direct reading gage spindle shall be in contact with the center of the direct tension indicator support block during the test (see Fig. 21).

5.6.6.3 *Zero Direct Reading Gage*—Place the direct tension indicator, with protrusions facing down, into the grooves of the support block. Apply compression load equal to the minimum required load for the size and type of direct tension indicator

being tested. Set the direct reading gage at zero. Release the load and remove the direct tension indicator. See Step 1 of Fig. 21.

5.6.6.4 Invert the support block so that Side A with the groove is facing down.

5.6.6.5 Measure Compression Load:

5.6.6.6 Place the flat surface of the direct tension indicator against side B of the support block with protrusions facing up. Apply compression load until the gage reading is the test gap specified for the size, type, and surface condition of the direct tension indicator being tested. See Step 2 of Fig. 21.

5.6.6.7 Apply the compression load at a rate such that the direct tension indicator is compressed within 30 s from the time the compression load is first applied until the proper gap is achieved.

5.6.6.8 *Read and Record*, Read the compression load within 5 s of reaching the test gap and record the results.

6. Rivets

6.1 *Product Hardness*—Determine hardness at the mid-radius of a transverse section of the product taken at a distance of one diameter from the point end of the rivet. Use either Brinell or Rockwell hardness tests, and measure as described in 3.1.

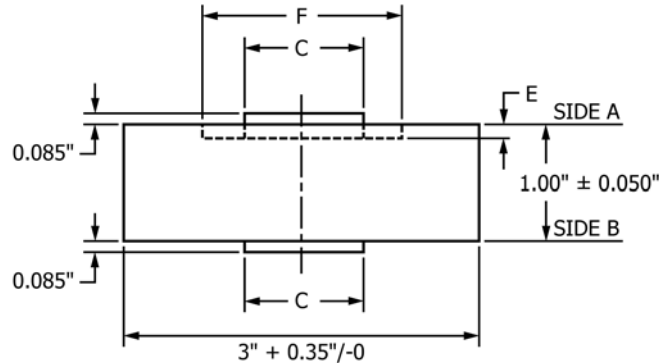

{ Height of boss = 0.085 in. +0/-0.0005 in. with no more than 0.0002 in. difference between side "A" and side "B" }

(1) Dimension 'A' and dimension 'B' shall be no less than 0.050 in., with no more than 0.0002 in. difference between the 'A' and 'B' sides of the same support block.

(2) Dimension 'C' shall be less than the inside diameter of the corresponding DTI to be tested.

(3) Dimension 'D' shall be no less than the greater of 3 in. or the outside diameter of the DTI to be tested.

(4) Dimension 'E' shall be at least 0.080 in., yet less than 0.165 in..

(5) Dimension 'F' shall be large enough to accept the DTI without interference with its protrusions, and no more than the value corresponding to the midpoint of the PTD and the O.D. of the DTI to be tested.

(6) Dimension 'G' shall be no less than 1 in.

Direct Tension Indicator Size, in.	C in.		E in.		F in.	
	max	min	max	min	max	min
1/2	0.485	0.475	0.130	0.080	0.96	0.91
5/8	0.615	0.605	0.145	0.095	1.15	1.10
3/4	0.735	0.725	0.150	0.100	1.34	1.29
7/8	0.855	0.845	0.150	0.100	1.54	1.49
1	0.985	0.975	0.165	0.115	1.73	1.68
1 1/8	1.105	1.095	0.165	0.115	1.93	1.88
1 1/4	1.225	1.215	0.165	0.115	2.12	2.07
1 3/8	1.355	1.345	0.165	0.115	2.31	2.26
1 1/2	1.475	1.465	0.165	0.115	2.51	2.46

FIG. 19 Inch DTI Support Block Dimensions

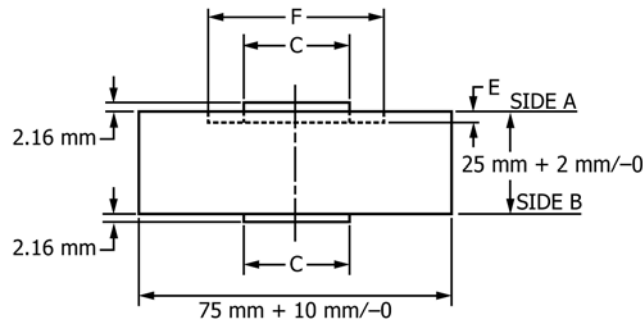

(Height of boss = 2.16 mm. +0/-0.0125 mm with no more than 0.005 mm difference between side "A" and side "B")

- (1) Dimension 'A' and dimension 'B' shall be no less than 1.25 mm, with no more than 0.005 mm difference between the 'A' and 'B' sides of the same support block.
- (2) Dimension 'C' shall be less than the inside diameter of the corresponding DTI to be tested.
- (3) Dimension 'D' shall be no less than the greater of 75 mm or the outside diameter of the DTI to be tested.
- (4) Dimension 'E' shall be at least 2.0 mm, yet less than 4.0 mm.
- (5) Dimension 'F' shall be large enough to accept the DTI without interference with its protrusions, and no more than the value corresponding to the midpoint of the PTD and the O.D. of the DTI to be tested.
- (6) Dimension 'G' shall be no less than 25mm.

Direct Tension Indicator Size	C mm		E mm		F mm	
	max	min	min	max	min	max
M16	15.5	15	3	30	30.5	
M20	19.5	19	3	34	34.5	
M22	21.5	21	3	38	38.5	
M24	23.5	23	3	43	43.5	
M27	26.5	26	3	49	49.5	
M30	29.5	29	3	53.5	54	
M36	35.5	35	3	63	63.5	

FIG. 20 Metric DTI Support Block Dimensions

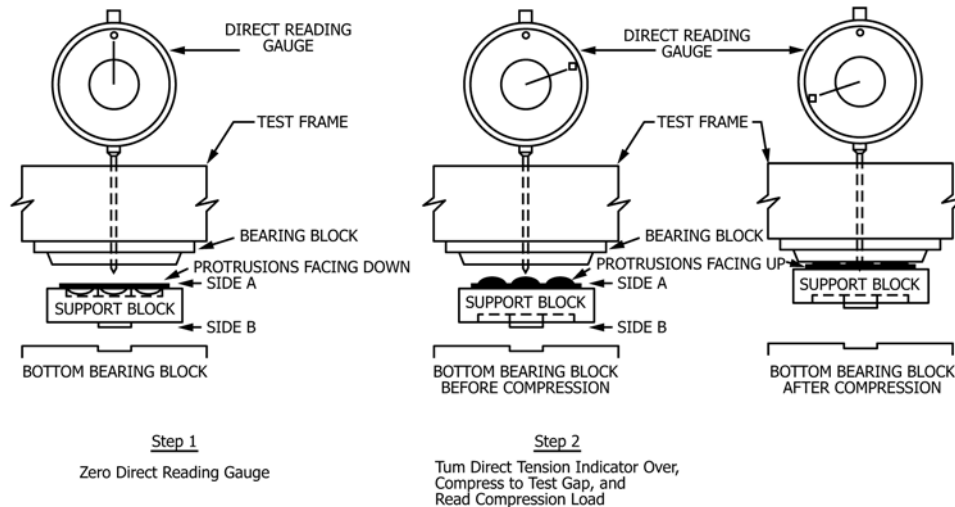

FIG. 21 Steps for Determining Compression Load

7. Test for Embrittlement of Metallic Coated Externally Threaded Fasteners

7.1 This is one test method for determining if embrittlement exists in a metallic coated externally threaded fastener covered by the product specifications of ASTM Committee F16.

7.2 The test fastener shall be installed in a test fixture (see Note 2 in Fig. 22) with the head positioned against the wedge, assembled with a nut, and tensioned (by means of the nut only) by any means capable of measuring tensile load. The torque

method described in 7.3 is one such method. The test samples shall be tensioned to 75 % of their specified minimum ultimate tensile strength. For studs with different thread pitches on either end, the finer thread pitch end shall be assembled with a nut and tested as the head end of the fastener.

7.2.1 The assembly shall remain in this tightened state for not less than 48 h, after which the test fastener shall be visually examined for embrittlement-induced failure, such as missing head.

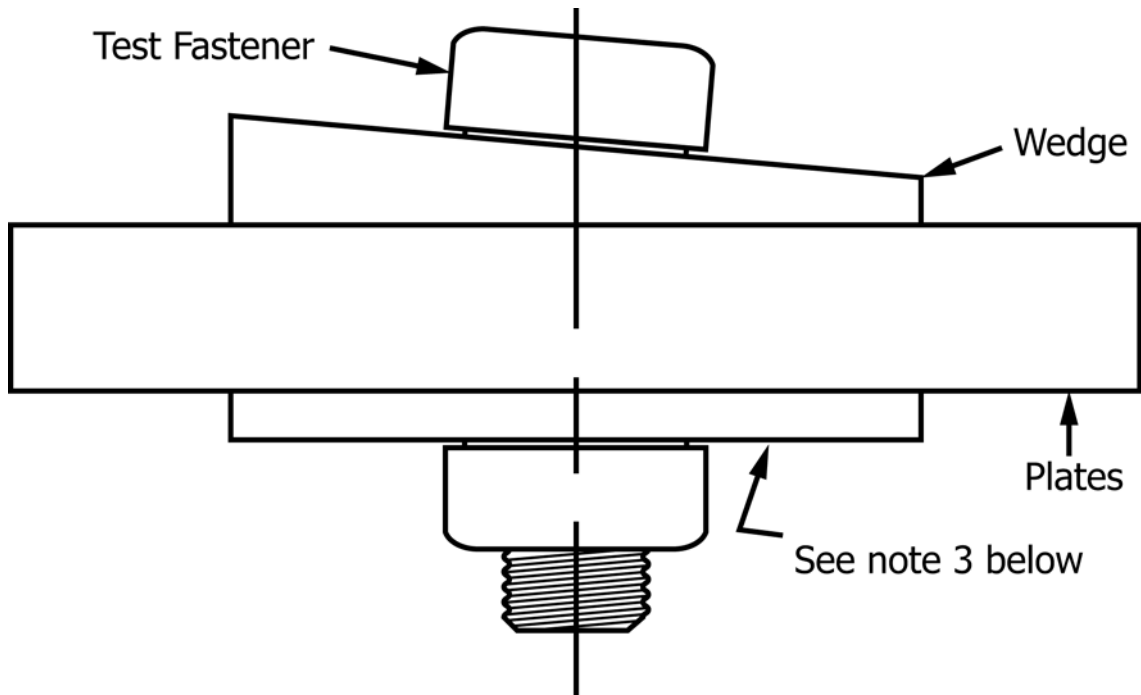

NOTE 1—The illustrated test fixture shown above reflects a single bolt under load. It should be noted, however, that test fixtures with multiple test locations are acceptable

NOTE 2—Work is continuing on this test method and revisions are anticipated. Additionally caution should be taken when applying this test procedure. The heads of embrittled fasteners may suddenly break off and become flying projectiles capable of causing serious injury or blinding.

NOTE 3—Hardened inch test washers shall have a maximum surface finish of 750 microinches and metric test washers shall have less than 0.19 micrometers.

FIG. 22 Test Fixture

7.2.2 The joint shall then be disassembled and the test fastener visually examined using a minimum of 20 power magnification for evidence of embrittlement failure, such as transverse cracks in the shank, threads or at the junction of head to shank.

7.2.3 For disassembly, if the torque method of tightening is used, torque shall be applied in the ON direction until the nut rotates a noticeable amount. The retightening torque with the nut in motion shall be measured and shall be no less than 90 % of the initial tightening torque.

7.2.4 If a direct tension method of tightening is used, then the loss of clamping strength in pounds or Newtons over the test period shall be no more than 10 % of the initial clamping load.

7.3 The test fixture shall comprise a hardened wedge (7.3.1), a plate(s) (7.3.2), and a hardened washer (7.3.3) (see Fig. 22).

7.3.1 The wedge shall have an angle as specified in Table 7 and Table 8. Other dimensions and properties shall be in conformance with hardened wedges described in 3.5.1.

TABLE 7 Test for Inch Fastener Embrittlement Wedge Angles, Degrees

Nominal Size of Fastener, dia	Studs and Fasteners with Unthreaded Lengths, Less Than 2 dia	Fasteners with Unthreaded Lengths, 2 dia and Longer
1/4 to 3/4 in.	4	6
Over 3/4 to 1-1/2 in.	0	4

TABLE 8 Test for Metric Fastener Embrittlement Wedge Angles, Degrees

Nominal Size of Fastener, dia	Studs and Fasteners with Unthreaded Lengths, Less Than 2 dia	Fasteners with Unthreaded Lengths, 2 dia and Longer
M5 through M20	4	6
Over M20	0	4

7.3.2 The plate(s) shall be steel and have a thickness such that, after installation and tightening, a minimum of three full threads of the test fastener will be in the grip. The hole in the plate(s) shall be as close to the major diameter of the fastener being tested as practical but not greater than the hole in the hardened washer (7.2.3).

7.3.3 The hardened washer shall be in conformance with Specification F436/F436M.

7.4 If the torque method of tightening is used, the tightening torque shall be determined using a load-measuring device capable of measuring the actual tension induced in a fastener as the fastener is tightened. Three fasteners from the test lot shall be selected at random. Each shall be assembled into the load-measuring device, mated with a nut, and the nut tightened until a load equal to 75 % of the specified minimum ultimate tensile strength of the fastener is induced. The torque required to induce this load shall be measured and the arithmetic average of the three measured torques shall be the tightening torque. The surface against which the nut is torqued should be

similar in hardness and finish to that of the test fixture (Fig. 22) and use of a hardened washer (7.3.3) is recommended.

7.5 To meet the requirements of this test the fastener shall show no evidence of embrittlement failure when visually examined and the retightening torque shall not be less than 90 % of the initial tightening torque.

NOTE 13—The nature of this test method is such that a fastener will either pass or fail as a result of being subjected to the test conditions. The qualitative nature of the test does not provide information on how close or how far a fastener is from failure. This test method is to be used for embrittlement testing on a production scale and is not to be used for analytical purposes. Test Method F1624 can be used as an analytical method to test fastener products in cases of uncertainty, or where quantitative or analytical data are required. Test Method F1624 is not suited for embrittlement testing on a production scale due to the time and costs associated with performing the test.

8. Test Method for Determining Decarburization and Carburization

8.1 See Test Method F2328 for inch fasteners and F2328M for metric fasteners.

9. Torsional Strength Test

9.1 Sample screws shall be tested using a suitable means such as shown in Fig. 23.

9.2 The split or solid fixture used to prevent the screw from rotating during testing shall be threaded to avoid screw thread damage. The confined screw length shall be equal to at least one screw diameter. At least two thread pitches shall be free between the top of the confining fixture and the under side of the screw’s head.

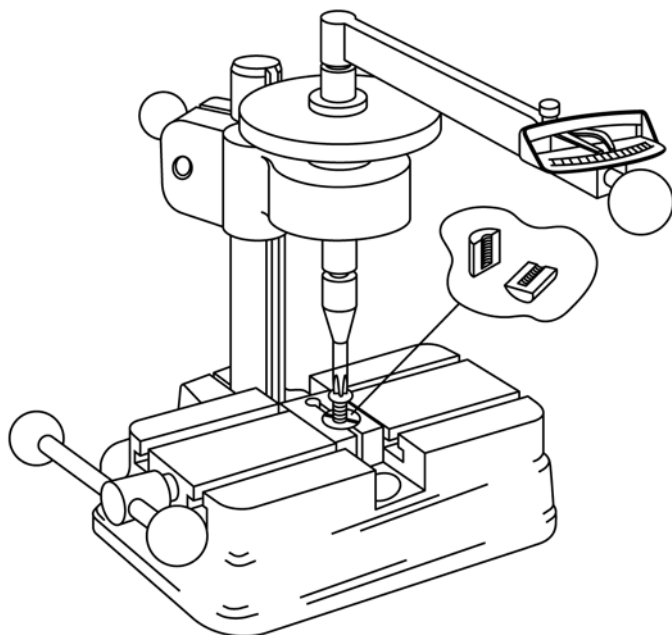

FIG. 23 Typical Torsional Strength Test Fixture

9.3 An appropriately calibrated torque measuring device shall be used to apply torque to the screw until it is twisted into two pieces. The screw’s torsional strength is the maximum value observed during the application of torque, which results in the required mode of failure.

9.4 This test applies only to screws that have a length equal to at least one body diameter plus two thread pitches or screws .375 in. or M10 or less, or both.

9.5 The required torsional strength values are provided in the applicable machine screw standards.

Torsional formula inches:

$$Mb = d^3 * UTS * 0.165 \tag{5}$$

Torsional formula metric:

$$Mb = d^3 * UTS * 0.00014 \tag{6}$$

where:

Mb = minimum torsional strength (inch pounds for inch fasteners and Nm for metric fasteners)

*d*³ = thread minor diameter (reference or minimum if available)

UTS = ultimate tensile strength (psi for inch fasteners and MPa for metric fasteners)

Inch Example: ¼ - 20 Grade 5

$$Mb = (0.1894)^3 * 120\,000 * 0.165,$$

$$Mb = .0067 * 120\,000 * 0.165,$$

$$Mb = 134 \text{ in./lbs.}$$

Metric Example: M10, 8.8,

$$Mb = (8.375)^3 * 800 \text{ MPa} * 0.00014,$$

$$Mb = 587 * 800 * 0.00014,$$

$$Mb = 66 \text{ Nm}$$

10. Certification

10.1 Certification shall include a statement that the sampled and provided fastener products were tested and inspected in accordance with the requirements of the individual product specification; referencing the specification number, year date of issue, and any applicable product identification symbols. In addition, the certificate shall include the results of all tests performed, the product specification, and any supplementary requirements or other requirements as designated in the purchase order.

10.2 A certificate printed from or used in electronic form from an electronic data interchange (EDI) transmission shall be regarded as having the same validity as an original document printed in the certifier’s facility. The content of the EDI transmitted document shall also conform to any existing EDI agreement between the purchaser and supplier.

10.3 Notwithstanding the absence of a signature, the organization submitting either the EDI transmission or paper copies of certificates of test is responsible for the content of the report.

11. Keywords

11.1 compression load; hardness; proof load; properties; tensile; testing; yield

SUMMARY OF CHANGES

Committee F16 has identified the location of selected changes to this standard since the last issue (F606–14a^{e1}) that may impact the use of this standard. (Approved September 1, 2016.)

- (1) Note 2 was added to 3.5.1.
- (2) 3.5.1 was revised to preclude use of yield strength tested fasteners for wedge tensile testing.

Committee F16 has identified the location of selected changes to this standard since the last issue (F606–14) that may impact the use of this standard. (Approved November 1, 2014.)

- (1) This revision is a combination of Test Methods F606 and Test Methods F606M to create one consolidated standard.
- (2) The changes to this standard are the addition of references to metric SI units for metric fasteners throughout the standard in addition to the inch-pound units for the inch fasteners.
- (3) Where inch tables existed separate metric tables have been introduced.

ASTM International takes no position respecting the validity of any patent rights asserted in connection with any item mentioned in this standard. Users of this standard are expressly advised that determination of the validity of any such patent rights, and the risk of infringement of such rights, are entirely their own responsibility.

This standard is subject to revision at any time by the responsible technical committee and must be reviewed every five years and if not revised, either reapproved or withdrawn. Your comments are invited either for revision of this standard or for additional standards and should be addressed to ASTM International Headquarters. Your comments will receive careful consideration at a meeting of the responsible technical committee, which you may attend. If you feel that your comments have not received a fair hearing you should make your views known to the ASTM Committee on Standards, at the address shown below.

This standard is copyrighted by ASTM International, 100 Barr Harbor Drive, PO Box C700, West Conshohocken, PA 19428-2959, United States. Individual reprints (single or multiple copies) of this standard may be obtained by contacting ASTM at the above address or at 610-832-9585 (phone), 610-832-9555 (fax), or service@astm.org (e-mail); or through the ASTM website (www.astm.org). Permission rights to photocopy the standard may also be secured from the Copyright Clearance Center, 222 Rosewood Drive, Danvers, MA 01923, Tel: (978) 646-2600; <http://www.copyright.com/>