

BS EN 14399-3:2015



BSI Standards Publication

High-strength structural bolting assemblies for preloading

Part 3: System HR — Hexagon bolt and nut
assemblies

bsi.

...making excellence a habit.™

National foreword

This British Standard is the UK implementation of EN 14399-3:2015. It supersedes BS EN 14399-3:2005 which is withdrawn.

The UK participation in its preparation was entrusted to Technical Committee FME/9/-/2, Fasteners for structural bolting.

A list of organizations represented on this committee can be obtained on request to its secretary.

This publication does not purport to include all the necessary provisions of a contract. Users are responsible for its correct application.

© The British Standards Institution 2015. Published by BSI Standards Limited 2015

ISBN 978 0 580 81779 3

ICS 21.060.01; 21.060.10; 21.060.20

Compliance with a British Standard cannot confer immunity from legal obligations.

This British Standard was published under the authority of the Standards Policy and Strategy Committee on 28 February 2015.

Amendments issued since publication

Date	Text affected
------	---------------

EUROPEAN STANDARD

EN 14399-3

NORME EUROPÉENNE

EUROPÄISCHE NORM

February 2015

ICS 21.060.01

Supersedes EN 14399-3:2005

English Version

High-strength structural bolting assemblies for preloading - Part 3: System HR - Hexagon bolt and nut assemblies

Boulonnerie de construction métallique à haute résistance
apte à la précontrainte - Partie 3 : Système HR - Boulons à
tête hexagonale (vis + écrou)

Hochfeste vorspannbare Garnituren für
Schraubverbindungen im Metallbau - Teil 3: System HR -
Garnituren aus Sechskantschrauben und -muttern

This European Standard was approved by CEN on 18 October 2014.

CEN members are bound to comply with the CEN/CENELEC Internal Regulations which stipulate the conditions for giving this European Standard the status of a national standard without any alteration. Up-to-date lists and bibliographical references concerning such national standards may be obtained on application to the CEN-CENELEC Management Centre or to any CEN member.

This European Standard exists in three official versions (English, French, German). A version in any other language made by translation under the responsibility of a CEN member into its own language and notified to the CEN-CENELEC Management Centre has the same status as the official versions.

CEN members are the national standards bodies of Austria, Belgium, Bulgaria, Croatia, Cyprus, Czech Republic, Denmark, Estonia, Finland, Former Yugoslav Republic of Macedonia, France, Germany, Greece, Hungary, Iceland, Ireland, Italy, Latvia, Lithuania, Luxembourg, Malta, Netherlands, Norway, Poland, Portugal, Romania, Slovakia, Slovenia, Spain, Sweden, Switzerland, Turkey and United Kingdom.



EUROPEAN COMMITTEE FOR STANDARDIZATION
COMITÉ EUROPÉEN DE NORMALISATION
EUROPÄISCHES KOMITEE FÜR NORMUNG

CEN-CENELEC Management Centre: Avenue Marnix 17, B-1000 Brussels

Contents

	Page
Foreword.....	3
Introduction	4
1 Scope	6
2 Normative references	6
3 Bolts	7
3.1 Dimensions of bolts.....	7
3.2 Specification for bolts and reference standard	11
3.3 Marking of bolts	11
4 Nuts	12
4.1 Dimensions of nuts.....	12
4.2 Specification for nuts and reference standards	14
4.3 Proof load values of nuts	15
4.4 Decarburization of the nut thread	15
4.5 Marking of nuts	15
5 Designation of the bolt/nut assemblies.....	16
6 Associated washers	16
7 Functional characteristics of the bolt/nut/washer(s) assembly.....	16
7.1 General.....	16
7.2 Maximum individual value of the bolt force during fitness for purpose test ($F_{bi,max}$).....	17
7.3 Values of angle $\Delta\theta_1$	17
7.4 Values of angle $\Delta\theta_2$	17
7.5 Individual values of the k -factor (k_i), mean value of the k -factor (k_m) and coefficient of variation of the k -factor (V_k)	17
7.5.1 Individual values of the k -factor (k_i) for k -class K1.....	17
7.5.2 Mean value of the k -factor (k_m) and coefficient of variation of the k -factor (V_k) for k -class K2	18
Annex A (normative) Clamp lengths and grip lengths	19
A.1 Clamp lengths for bolting assemblies with one or two washers.....	19
A.2 Grip lengths for bolting assemblies with one or two washers	22
Bibliography	28

Foreword

This document (EN 14399-3:2015) has been prepared by Technical Committee CEN/TC 185 "Fasteners", the secretariat of which is held by DIN.

This European Standard shall be given the status of a national standard, either by publication of an identical text or by endorsement, at the latest by August 2015 and conflicting national standards shall be withdrawn at the latest by November 2016.

Attention is drawn to the possibility that some of the elements of this document may be the subject of patent rights. CEN [and/or CENELEC] shall not be held responsible for identifying any or all such patent rights.

This document supersedes EN 14399-3:2005.

In comparison with EN 14399-3:2005, the following modifications have been made:

- Table 1 containing the overview of the composition of bolting assemblies and component marking has been added;
- the coefficient of variation of the k -factor, V_k , was changed from 0,10 to 0,06;
- specifications for the designation of the bolting assemblies have been revised;
- Annex A with detailed specifications on clamp lengths and grip lengths has been added.

EN 14399 consists of the following parts, under the general title *High-strength structural bolting assemblies for preloading*:

- *Part 1: General requirements*;
- *Part 2: Suitability for preloading*;
- *Part 3: System HR — Hexagon bolt and nut assemblies*;
- *Part 4: System HV — Hexagon bolt and nut assemblies*;
- *Part 5: Plain washers*;
- *Part 6: Plain chamfered washers*;
- *Part 7: System HR — Countersunk head bolt and nut assemblies*;
- *Part 8: System HV — Hexagon fit bolt and nut assemblies*;
- *Part 9: System HR or HV — Direct tension indicators for bolt and nut assemblies*;
- *Part 10: System HRC — Bolt and nut assemblies with calibrated preload*.

According to the CEN-CENELEC Internal Regulations, the national standards organizations of the following countries are bound to implement this European Standard: Austria, Belgium, Bulgaria, Croatia, Cyprus, Czech Republic, Denmark, Estonia, Finland, Former Yugoslav Republic of Macedonia, France, Germany, Greece, Hungary, Iceland, Ireland, Italy, Latvia, Lithuania, Luxembourg, Malta, Netherlands, Norway, Poland, Portugal, Romania, Slovakia, Slovenia, Spain, Sweden, Switzerland, Turkey and the United Kingdom.

Introduction

This document on structural bolting reflects the situation in Europe where two technical solutions exist to achieve the necessary ductility of bolt/nut/washer(s) assemblies. These solutions consist of two different systems (HR and HV) of bolt/nut/washer assemblies, see Table 1. Both systems are well proven and it is the responsibility of the experts using structural bolting whether they use the one or the other system.

It is, however, important for the performance of the assembly to avoid mixing up the components of both systems. Therefore, bolts and nuts for both systems are standardized in one single part of this European Standard each and the marking of the components of the same system is uniform.

Preloaded bolted assemblies are very sensitive to differences in manufacture and lubrication. Therefore it is important that the bolting assemblies are supplied by one manufacturer who is always responsible for the functionality of the bolting assemblies.

For the same reason it is important that coating of the bolting assemblies is under the control of one manufacturer.

Beside the mechanical properties of the components, the functionality of the bolting assemblies requires that the specified preload can be achieved if the bolting assemblies are tightened with a suitable procedure. For this purpose a test method for the suitability of the bolting assemblies for preloading was created, which will demonstrate whether the functionality of the bolting assemblies is fulfilled.

It should be pointed out that compared to ISO 272 the widths across flats (large series) for M12 and M20 have been changed to 22 mm and 32 mm respectively. These changes are justified by the following reasons.

Under the specific conditions of structural bolting, the compressive stresses under the bolt head or nut for the sizes M12 may become too large with the width across flats of 21 mm, especially if the washer is fitted eccentrically to the bolt axis.

For the size M20, the width across flats of 34 mm is very difficult to be produced. The change to 32 mm is primarily motivated by economics but it should also be pointed out that the width across flats of 32 mm was common practice in Europe.

Table 1 — Composition of high-strength structural bolting assemblies and component marking

Type of bolting assembly		System HR				System HV		System HRC	
General requirements		EN 14399-1							
Suitability for preloading		EN 14399-2 and, if any, additional testing specified in the product standard							
Bolt and nut		EN 14399-3		EN 14399-7		EN 14399-4	EN 14399-8	EN 14399-10	
Marking	Bolt	HR8.8	HR10.9	HR8.8	HR10.9	HV10.9	HVP10.9	HRC10.9	
	Nut	HR8 or HR10	HR10	HR8 or HR10	HR10	HV10	HV10	HR10	HRD10
Washer(s)		EN 14399-5 ^a or EN 14399-6				EN 14399-6			EN 14399-5 ^a or EN 14399-6
Marking		H or HR ^b				H or HV ^b		H or HR ^b	H or HR ^b or HD ^c
Direct tension indicator and nut face washer or bolt face washer, if any		EN 14399-9						Not applicable	
Marking	Direct tension indicator	H8	H10	H8	H10	H10			
	Nut face washer	HN				HN			
	Bolt face washer	HB		Not applicable		HB			
^a EN 14399-5 can only be used under the nut. ^b At the choice of the manufacturer. ^c Mandatory mark for washers with enlarged outer diameter according to EN 14399-5 only.									

1 Scope

This European Standard specifies, together with EN 14399-1 and EN 14399-2, the requirements for assemblies of high-strength structural bolts and nuts of system HR suitable for preloaded joints with large widths across flats, thread sizes M12 to M36 and property classes 8.8/8 or 8.8/10 and 10.9/10.

Bolting assemblies in accordance with this document have been designed to allow preloading of at least $0,7 f_{ub} \times A_s$ ¹⁾ according to EN 1993-1-8 (Eurocode 3) and to obtain ductility predominantly by plastic elongation of the bolt. For this purpose the components have the following characteristics:

- normal nut height (style 1), see EN ISO 4032;
- thread length of the bolt according to ISO 888.

Bolting assemblies in accordance with this document include washers according to EN 14399-6 or to EN 14399-5 (under the nut only).

NOTE Attention is drawn to the importance of ensuring that bolting assemblies are correctly used if satisfactory results are to be obtained. For recommendations concerning proper application, reference to EN 1090-2 is made.

General requirements and requirements for suitability for preloading are specified in EN 14399-2.

Clamp lengths and grip lengths for the bolting assemblies are specified in the normative Annex A.

2 Normative references

The following documents, in whole or in part, are normatively referenced in this document and are indispensable for its application. For dated references, only the edition cited applies. For undated references, the latest edition of the referenced document (including any amendments) applies.

EN 14399-1, *High-strength structural bolting assemblies for preloading - Part 1: General requirements*

EN 14399-2, *High-strength structural bolting assemblies for preloading - Part 2: Suitability for preloading*

EN 14399-5, *High-strength structural bolting assemblies for preloading - Part 5: Plain washers*

EN 14399-6, *High-strength structural bolting assemblies for preloading - Part 6: Plain chamfered washers*

EN 26157-1, *Fasteners - Surface discontinuities - Part 1: Bolts, screws and studs for general requirements (ISO 6157-1)*

EN ISO 898-1, *Mechanical properties of fasteners made of carbon steel and alloy steel - Part 1: Bolts, screws and studs with specified property classes - Coarse thread and fine pitch thread (ISO 898-1)*

EN ISO 898-2, *Mechanical properties of fasteners made of carbon steel and alloy steel - Part 2: Nuts with specified property classes - Coarse thread and fine pitch thread (ISO 898-2)*

EN ISO 3269, *Fasteners - Acceptance inspection (ISO 3269)*

EN ISO 4759-1, *Tolerances for fasteners - Part 1: Bolts, screws, studs and nuts - Product grades A, B and C (ISO 4759-1)*

EN ISO 6157-2, *Fasteners - Surface discontinuities - Part 2: Nuts (ISO 6157-2)*

1) f_{ub} is the nominal tensile strength (R_m) and A_s the nominal stress area of the bolt.

EN ISO 10684, *Fasteners - Hot dip galvanized coatings (ISO 10684)*

ISO 261, *ISO general purpose metric screw threads - General plan*

ISO 965-2, *ISO general purpose metric screw threads - Tolerances - Part 2: Limits of sizes for general purpose external and internal screw threads - Medium quality*

ISO 965-5, *ISO general purpose metric screw threads - Tolerances - Part 5: Limits of sizes for internal screw threads to mate with hot-dip galvanized external screw threads with maximum size of tolerance position h before galvanizing*

ISO 3508, *Thread run-outs for fasteners with thread in accordance with ISO 261 and ISO 262*

3 Bolts

3.1 Dimensions of bolts

See Figure 1 and Table 2.

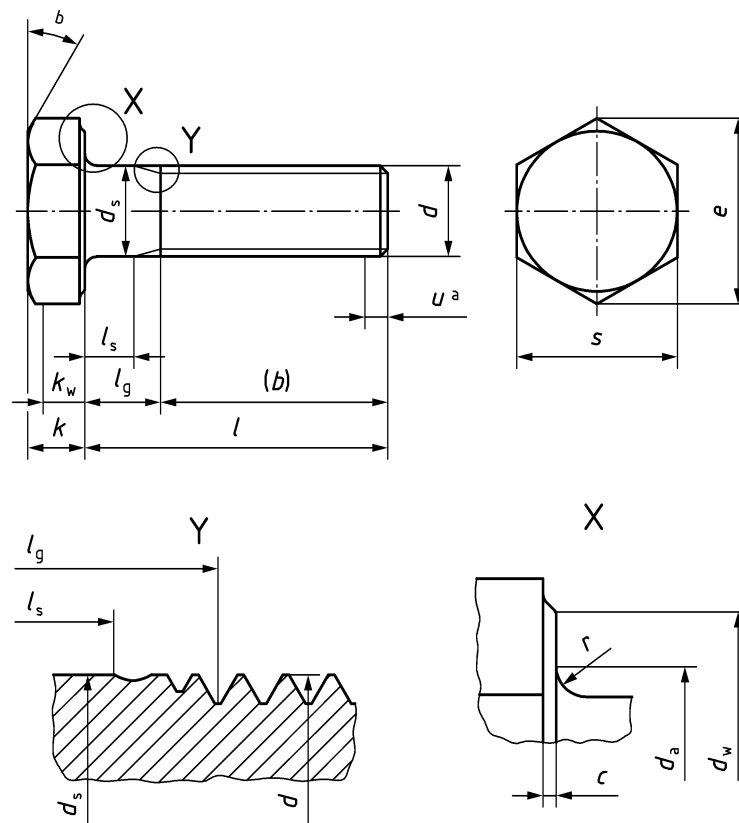

Key

- a incomplete thread $u \leq 2P$
- b 15° to 30°

Figure 1 — Dimensions of bolts

The difference between l_g and l_s should not be less than $1,5 P$.

For coated bolts, the dimensions apply prior to coating.

Table 2 — Dimensions of bolts

Dimensions in millimetres

Thread (<i>d</i>)			M12	(M14) ^a	M16	(M18) ^a	M20						
<i>P</i> ^b			1,75	2	2	2,5	2,5						
<i>b</i> (ref.)	^c		30	34	38	42	46						
	^d		—	40	44	48	52						
	^e		—	—	—	—	65						
<i>c</i>	max.		0,8	0,8	0,8	0,8	0,8						
	min.		0,4	0,4	0,4	0,4	0,4						
<i>d_a</i>	max.		15,2	17,2	19,2	21,7	24,4						
<i>d_s</i>	max.		12,70	14,70	16,70	18,70	20,84						
	min.		11,30	13,30	15,30	17,30	19,16						
<i>d_w</i>	max.		f	f	f	f	f						
	min.		20,1	22,0	24,9	27,7	29,5						
<i>e</i>	min.		23,91	26,17	29,56	32,95	35,03						
<i>k</i>	nom.		7,5	8,8	10	11,5	12,5						
	max.		7,95	9,25	10,75	12,40	13,40						
	min.		7,05	8,35	9,25	10,60	11,60						
<i>k_w</i>	min.		4,90	5,85	6,50	7,42	8,10						
<i>r</i>	min.		1,2	1,2	1,2	1,5	1,5						
<i>s</i>	max.		22	24	27	30	32						
	min.		21,16	23,16	26,16	29,16	31,00						
<i>l</i>	<i>l_s</i> and <i>l_g</i> ^{g, h}												
	nom.	min.	max.	<i>l_s</i> min.	<i>l_g</i> max.	<i>l_s</i> min.	<i>l_g</i> max.	<i>l_s</i> min.	<i>l_g</i> max.	<i>l_s</i> min.	<i>l_g</i> max.	<i>l_s</i> min.	<i>l_g</i> max.
35	33,75	36,25	—	7									
40	38,75	41,25	—	7				—	8				
45	43,75	46,25	6,25	15				—	8				
50	48,75	51,25	11,25	20	—	8	—	8			—	10	
55	53,5	56,5	16,25	25	11	21	—	8			—	10	
60	58,5	61,5	21,25	30	16	26	12	22	—	10	—	10	
65	63,5	66,5	26,25	35	21	31	17	27	10,5	23	—	10	
70	68,5	71,5	31,25	40	26	36	22	32	15,5	28	11,5	24	
75	73,5	76,5	36,25	45	31	41	27	37	20,5	33	16,5	29	
80	78,5	81,5	41,25	50	36	46	32	42	25,5	38	21,5	34	
85	83,25	86,75	46,25	55	41	51	37	47	30,5	43	26,5	39	
90	88,25	91,75	51,25	60	46	56	42	52	35,5	48	31,5	44	
95	93,25	96,75	56,25	65	51	61	47	57	40,5	53	36,5	49	
100	98,25	101,75	61,25	70	56	66	52	62	45,5	58	41,5	54	

110	108,25	111,75			66	76	62	72	55,5	68	51,5	64
120	118,25	121,75			76	86	72	82	65,5	78	61,5	74
130	128	132			80	90	76	86	69,5	82	65,5	78
140	138	142			90	100	86	96	79,5	92	75,5	88
150	148	152			100	110	96	106	89,5	102	85,5	98
160	156	164			110	120	106	116	99,5	112	95,5	108

Thread (<i>d</i>)			M22	M24	M27	M30	M36						
<i>p^b</i>			2,5	3	3	3,5	4						
<i>b</i> (ref.)	<i>c</i>		50	54	60	66	78						
	<i>d</i>		56	60	66	72	84						
	<i>e</i>		69	73	79	85	97						
<i>c</i>	max.		0,8	0,8	0,8	0,8	0,8						
	min.		0,4	0,4	0,4	0,4	0,4						
<i>d_a</i>	max.		26,4	28,4	32,4	35,4	42,4						
<i>d_s</i>	max.		22,84	24,84	27,84	30,84	37,00						
	min.		21,16	23,16	26,16	29,16	35,00						
<i>d_w</i>	max.	<i>f</i>	<i>f</i>	<i>f</i>	<i>f</i>	<i>f</i>	<i>f</i>						
	min.		33,3	38,0	42,8	46,6	55,9						
<i>e</i>	min.		39,55	45,20	50,85	55,37	66,44						
<i>k</i>	nom.		14	15	17	18,7	22,5						
	max.		14,90	15,90	17,90	19,75	23,55						
	min.		13,10	14,10	16,10	17,65	21,45						
<i>k_w</i>	min.		9,2	9,9	11,3	12,4	15,0						
<i>r</i>	min.		1,5	1,5	2,0	2,0	2,0						
<i>s</i>	max.		36	41	46	50	60						
	min.		35,0	40,0	45,0	49,0	58,8						
<i>l</i>			<i>l_s</i> and <i>l_g^{g, h}</i>										
	nom.	min.	max.	<i>l_s</i> min.	<i>l_g</i> max.	<i>l_s</i> min.	<i>l_g</i> max.	<i>l_s</i> min.	<i>l_g</i> max.	<i>l_s</i> min.	<i>l_g</i> max.	<i>l_s</i> min.	<i>l_g</i> max.
50	48,75	51,25	–	10									
55	53,5	56,5	–	10									
60	58,5	61,5	–	10	–	12	–	12					
65	63,5	66,5	–	10	–	12	–	12					
70	68,5	71,5	–	10	–	12	–	12	–	14			
75	73,5	76,5	12,5	25	–	12	–	12	–	14			
80	78,5	81,5	17,5	30	–	12	–	12	–	14			
85	83,25	86,75	22,5	35	16	31	–	12	–	14	–	16	
90	88,25	91,75	27,5	40	21	36	15	30	–	14	–	16	

95	93,25	96,75	32,5	45	26	41	20	35	–	14	–	16
100	98,25	101,75	37,5	50	31	46	25	40	16,5	34	–	16
110	108,25	111,75	47,5	60	41	56	35	50	26,5	44	–	16
120	118,25	121,75	57,5	70	51	66	45	60	36,5	54	22	42
130	128	132	61,5	74	55	70	49	64	40,5	58	26	46
140	138	142	71,5	84	65	80	59	74	50,5	68	36	56
150	148	152	81,5	94	75	90	69	84	60,5	78	46	66
160	156	164	91,5	104	85	100	79	94	70,5	88	56	76
170	166	174			95	110	89	104	80,5	98	66	86
180	176	184			105	120	99	114	90,5	108	76	96
190	186	194			115	130	109	124	100,5	118	86	106
200	196	204			125	140	119	134	110,5	128	96	116

NOTE 1 Preferred lengths are defined in terms of lengths $l_{s,min}$ and $l_{g,max}$.

^a Non-preferred sizes.

^b P is the pitch of thread.

^c For lengths $l_{nom} \leq 125$ mm.

^d For lengths $125 \text{ mm} < l_{nom} \leq 200$ mm.

^e For lengths $l_{nom} > 200$ mm.

^f $d_{w,max} = s_{actual}$

^g $l_{g,max} = l_{nom} - b$ $l_{s,min} = l_{g,max} - 5P$

^h When $l_{s,min}$ as calculated by the formula in ^g is less than $0,5d$ then the bolts be fully threaded, and in this case $l_{g,max}$ is equal to a_{max} as specified in ISO 3508 for product grade C, i.e. $4P$. Fully threaded bolts are shown above the stepped line.

3.2 Specification for bolts and reference standard

Table 3 — Specifications for bolts and reference standards

Material		Steel
General requirements		EN 14399-1 and EN 14399-2
Thread	Tolerance class	6g ^a
	International Standards	ISO 261, ISO 965-2
Mechanical properties	Property class	8.8 or 10.9
	European Standard	EN ISO 898-1
Tolerances	Product grade	C except for dimensions <i>c</i> and <i>r</i> . Tolerance for lengths ≥ 160 mm: $\pm 4,0$ mm
	European Standard	EN ISO 4759-1
Finish — Coating^b	Uncoated	As processed ^c
	Hot dip galvanized	EN ISO 10684
	Others	To be agreed ^d
Surface integrity		Limits for surface discontinuities as specified in EN 26157-1.
Acceptability		For acceptance procedure, see EN ISO 3269.
^a The tolerance class specified applies to bolts without or before any coating. Hot-dip galvanized bolts are intended for assembly with nuts tapped oversize to 6AZ. ^b Attention is drawn to the need to consider the risk of hydrogen embrittlement in the case of bolts of property class 10.9, when selecting an appropriate surface treatment process (e.g. cleaning and coating), see the relevant coating standards. ^c “As processed” means the normal finish resulting from manufacture with a light coating of oil. ^d Other coatings may be negotiated between the purchaser and the manufacturer provided they do not impair the mechanical properties or the functional characteristics. Coatings of cadmium or cadmium alloy are not permitted.		

3.3 Marking of bolts

High-strength structural bolts according to this part of this document shall be marked with:

- a) property class marking in accordance with EN ISO 898-1 and the letters HR;

EXAMPLE 10.9 HR.

- b) the identification mark of the manufacturer of the bolting assembly.

It is permissible for the marking to be either embossed or indented on the top surface of the head. For bolt marking, see Figure 2:

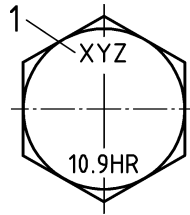

Key

- 1 identification mark of the manufacturer of the bolting assembly

Figure 2 — Example of bolt marking

4 Nuts

4.1 Dimensions of nuts

See Figure 3 and Table 4.

Alternative form permissible

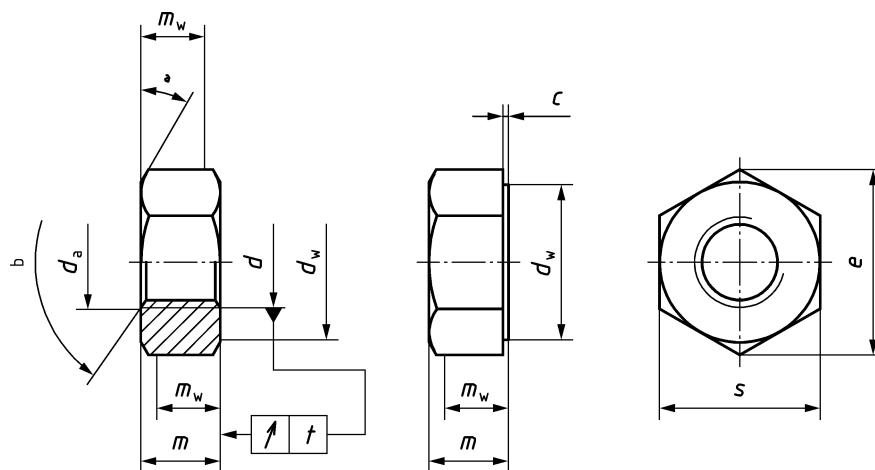

Key

- a 15° to 30°
- b 110° to 130°

Figure 3 — Dimensions of nuts

For coated nuts the above dimensions apply prior to coating.

Table 4 — Dimensions of nuts

Dimensions in millimetres

Thread (<i>d</i>)		M12	(M14) ^a	M16	(M18) ^a	M20	M22	M24	M27	M30	M36
<i>P</i> ^b		1,75	2	2	2,5	2,5	2,5	3	3	3,5	4
<i>d_a</i>	max.	13,0	15,1	17,3	19,5	21,6	23,7	25,9	29,1	32,4	38,9
	min.	12	14	16	18	20	22	24	27	30	36
<i>d_w</i>	max.	^c	^c	^c	^c	^c	^c	^c	^c	^c	^c
	min.	20,10	21,86	24,90	27,70	29,50	33,30	38,00	42,80	46,60	55,90
<i>e</i>	min.	23,91	27,12	29,56	32,95	35,03	39,55	45,20	50,85	55,37	66,44
<i>m</i>	max.	10,8	12,8	14,8	15,8	18,0	19,4	21,5	23,8	25,6	31,0
	min.	10,37	12,10	14,10	15,10	16,90	18,10	20,20	22,50	24,30	29,40
<i>m_w</i>	min.	8,3	9,7	11,3	12,1	13,5	14,5	16,2	18,1	19,5	22,4
<i>c</i>	max.	0,8	0,8	0,8	0,8	0,8	0,8	0,8	0,8	0,8	0,8
	min.	0,4	0,4	0,4	0,4	0,4	0,4	0,4	0,4	0,4	0,4
<i>s</i>	max.	22	24	27	30	32	36	41	46	50	60
	min.	21,16	23,16	26,16	29,16	31,00	35,00	40,00	45,00	49,00	58,80
<i>t</i>		0,38	0,42	0,47	0,52	0,58	0,63	0,72	0,80	0,87	1,05
^a Non-preferred sizes. ^b <i>P</i> is the pitch of thread. ^c <i>d_{w,max}</i> = 'actual'											

4.2 Specification for nuts and reference standards

Table 5 — Specifications for nuts and reference standards

Material		Steel		
General requirements		EN 14399-1 and EN 14399-2		
Thread	Coating of the bolt	Uncoated	Hot dip galvanized	Others
	Tolerance class of the nut	6H	6AZ	6H ^a
	International Standards	ISO 261, ISO 965-2	ISO 261, ISO 965-5	ISO 261, ISO 965-2, ISO 965-5
Mechanical properties	Property class	8 ^b or 10 ^b		
	European Standard	EN ISO 898-2		
Tolerances	Product grade	B except for dimensions <i>m</i> and <i>c</i>		
	European Standard	EN ISO 4759-1 ^c		
Finish — Coating	Uncoated	As processed ^d		
	Hot dip galvanized	EN ISO 10684		
	Others	To be agreed ^e		
Surface integrity		Limits for surface discontinuities as specified in EN ISO 6157-2.		
Acceptability		For acceptance procedure, see EN ISO 3269.		
<p>^a For other coatings that need an increased fundamental deviation and according to the relevant standard, oversize tapped nuts with a thread tolerance class up to 6AZ may be used.</p> <p>^b For mechanical properties other than those specified in EN ISO 898-2, see 4.3, Table 6 for proof load values and Table 7 for hardness values.</p> <p>^c Except tolerance on perpendicularity of bearing face, see tolerance <i>t</i> in Table 4.</p> <p>^d “As processed” means the normal finish resulting from manufacture with a light coating of oil.</p> <p>^e Other coatings may be negotiated between the purchaser and the manufacturer provided they do not impair the mechanical properties or the functional characteristics. Coatings of cadmium or cadmium alloys are not permitted.</p>				

4.3 Proof load values of nuts

Table 6 — Proof load values of nuts

Thread (d)	Nominal stress area of standard test mandrel A_s mm ²	Property class	
		8	10
		Tolerance class 6H to 6AZ	Tolerance class 6H to 6AZ
		Proof load ($A_s \times S_p$), N	
M12	84,3	84 300	97 800
(M14)	115	115 000	133 400
M16	157	157 000	182 100
(M18)	192	192 000	222 700
M20	245	245 000	284 200
M22	303	303 000	351 200
M24	353	353 000	409 500
M27	459	459 000	532 400
M30	561	561 000	650 800
M36	817	817 000	947 700

NOTE The proof load values are based on the following stress under proof load (S_p):
 — for nuts of property class 8: 1 000 N/mm²
 — for nuts of property class 10: 1 160 N/mm²

Where nuts are to be accepted on the basis of hardness values, the appropriate limits are those specified in Table 7.

Table 7 — Hardness values of nuts, if specified

Nut	Hardness limits
Property class 8, tolerance class 6H	As specified in EN ISO 898-2 for property class 8
Property class 10, tolerance class 6H or 6AZ	As specified in EN ISO 898-2 for property class 10
Property class 8, tolerance class 6AZ, hot dip galvanized	260 HV to 353 HV (24 HRC to 36 HRC)

4.4 Decarburization of the nut thread

The decarburization of the nut thread, when measured in analogy to external threads, as given in EN ISO 898-1, shall not exceed $G = 0,015$ mm.

4.5 Marking of nuts

High-strength structural nuts according to this document shall be marked with:

- a) property class marking in accordance with EN ISO 898-2 and the letters HR;

EXAMPLE 10 HR.

b) the identification mark of the manufacturer of the bolting assembly.

The marking shall be indented on either bearing face of chamfered nuts and shall be either indented or embossed on the non-bearing face of washer faced nuts. For nut marking, see Figure 4:

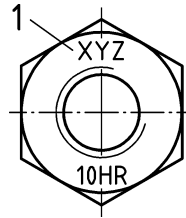

Key

1 identification mark of the manufacturer of the bolting assembly

Figure 4 — Example of nut marking

5 Designation of the bolt/nut assemblies

The designation of bolt/nut assemblies is specified in this clause. The complete designation for bolting assemblies includes washers specified in EN 14399-6 and/or EN 14399-5.

EXAMPLE 1 Designation of a bolt/nut assembly for high strength structural bolting for preloading, system HR, consisting of a hexagon head bolt with large width across flats, with thread M16, nominal length $l = 80$ mm and property class 8.8 and a hexagon nut with large width across flats, with thread M16 and property class 10, with surface finish „as processed”, according to k -class K0 (e.g.: For use with direct tension indicator in accordance with EN 14399-9.):

Bolt/nut assembly EN 14399-3 — HR — M16 × 80 — 8.8/10 — K0

EXAMPLE 2 Designation of a bolt/nut assembly for high strength structural bolting for preloading, system HR, consisting of a hexagon head bolt with large width across flats, with thread M16, nominal length $l = 80$ mm and property class 10.9 and a hexagon nut with large width across flats, with thread M16 and property class 10, with hot dip galvanized coating (tZn), according to k -class K2:

Bolt/nut assembly EN 14399-3 — HR — M16 × 80 — 10.9/10 — tZn — K2

6 Associated washers

Bolt/nut assemblies according to this document shall be assembled with washers specified in EN 14399-6 and/or EN 14399-5 (under the nut only).

7 Functional characteristics of the bolt/nut/washer(s) assembly

7.1 General

The functional characteristics of the bolt/nut/washer(s) assemblies according to 7.2 and 7.4 shall be achieved for all k -classes when tested in accordance with EN 14399-2.

Additionally for K1, 7.5.1 shall apply and for K2, 7.5.2 shall apply.

Minimum clamp lengths are specified in Annex A (see Table A.1).

NOTE For further background information as to these functional characteristics, see EN 14399-2.

The bolting assembly shall be suitably lubricated in the as delivered condition, to ensure that seizure will not take place during tightening of the assembly and that the required preload is obtained.

7.2 Maximum individual value of the bolt force during fitness for purpose test ($F_{bi,max}$)

The following applies:

$$F_{bi,max} \geq 0,9 f_{ub} \times A_s$$

where

f_{ub} is the nominal tensile strength (R_m);

A_s is the nominal stress area of the bolt.

7.3 Values of angle $\Delta\theta_1$

$\Delta\theta_1$ is the angle by which the nut shall be turned starting from a preload of $0,7 f_{ub} \times A_s$ until $F_{bi,max}$ is reached.

The values indicated in Table 8 are for information only.

Table 8 — Values for $\Delta\theta_1$

Clamp length Σt^a	$\Delta\theta_1$ min.
$\Sigma t < 2 d$	90°
$2 d \leq \Sigma t < 6 d$	120°
$6 d \leq \Sigma t \leq 10 d$	150°

^a Σt is the total thickness of the clamped parts including washer(s).

7.4 Values of angle $\Delta\theta_2$

$\Delta\theta_2$ is the angle by which the nut shall be turned, starting from a preload of $0,7 f_{ub} \times A_s$ through $F_{bi,max}$ and until F_{bi} has dropped to $0,7 f_{ub} \times A_s$.

The values for $\Delta\theta_2$ specified in Table 9 apply.

Table 9 — Values for $\Delta\theta_2$

Clamp length Σt^a	$\Delta\theta_2$ min.
$\Sigma t < 2 d$	210°
$2 d \leq \Sigma t < 6 d$	240°
$6 d \leq \Sigma t \leq 10 d$	270°

^a Σt is the total thickness of the clamped parts including washer(s).

7.5 Individual values of the k -factor (k_i), mean value of the k -factor (k_m) and coefficient of variation of the k -factor (V_k)

7.5.1 Individual values of the k -factor (k_i) for k -class K1

For k -class K1, the k_i values shall be within the range of $0,10 \leq k_i \leq 0,16$.

7.5.2 Mean value of the k -factor (k_m) and coefficient of variation of the k -factor (V_k) for k -class K2

The mean value (k_m) of the k -factor shall be calculated as follows:

$$k_m = \frac{\sum_{i=1}^n k_i}{n}$$

with

$$k_i = \frac{M_{pi}}{F_{p,C} \times d}$$

where

M_{pi} is the individual value of the applied torque;

$F_{p,C}$ is the required preload;

d is the nominal bolt diameter.

The coefficient of variation of the k -factor (V_k) shall be calculated as follows:

$$V_k = \frac{s_k}{k_m}$$

where

s_k is the standard deviation $\left(s_k = \sqrt{\frac{\sum (k_i - k_m)^2}{n - 1}} \right)$

For k_m and V_k the following values apply:

$$0,10 \leq k_m \leq 0,23$$

$$V_k \leq 0,06$$

Annex A
(normative)

Clamp lengths and grip lengths

A.1 Clamp lengths for bolting assemblies with one or two washers

See Figure A.1 and Table A.1.

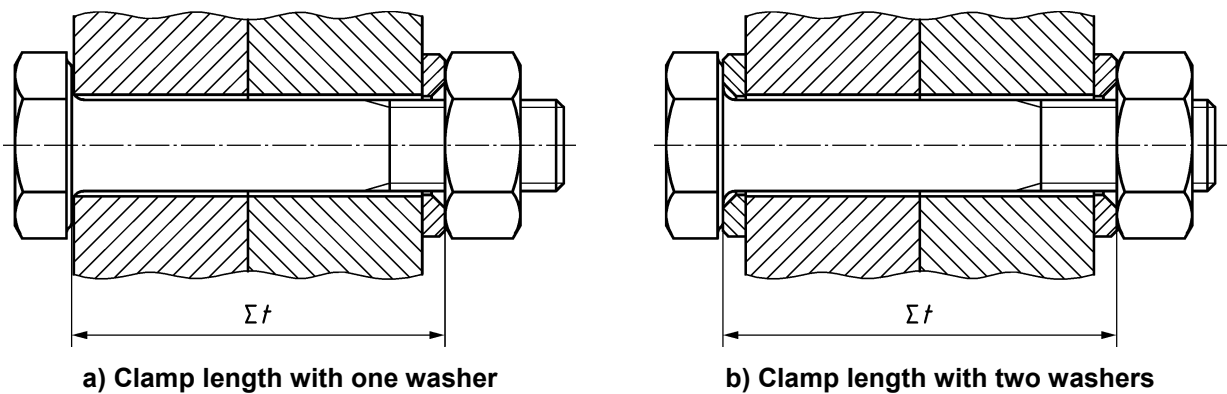

Figure A.1 — Clamp Length Σt

NOTE 1 Clamp length is not affected by the number of washers.

NOTE 2 The number of washers is dependent on the specific application as specified in EN 1090-2.

Table A.1 — Clamp Length with one or two washers Σl

Dimensions in millimetres

Thread (<i>d</i>)			M12		(M14)		M16		(M18)		M20		M22		M24		M27		M30		M36	
<i>l</i>			Σl_{\min} and Σl_{\max}																			
nom.	min.	max.	min.	max.	min.	max.	min.	max.	min.	max.	min.	max.	min.	max.	min.	max.	min.	max.	min.	max.	min.	max.
35	33,75	36,25	14	21																		
40	38,75	41,25	14	26			16	21														
45	43,75	46,25	22	31			16	26														
50	48,75	51,25	27	36	16	33	16	31			20	28	20	26								
55	53,5	56,5	32	40	29	38	16	36			20	33	20	31								
60	58,5	61,5	37	45	34	43	30	41	20	40	20	38	20	36	24	34	24	31				
65	63,5	66,5	42	50	39	48	35	46	33	45	20	43	20	41	24	39	24	36				
70	68,5	71,5	47	55	44	53	40	51	38	50	34	48	20	46	24	44	24	41	28	39		
75	73,5	76,5	52	60	49	58	45	56	43	55	39	53	35	51	24	49	24	46	28	44		
80	78,5	81,5	57	65	54	63	50	61	48	60	44	58	40	56	24	54	24	51	28	49		
85	83,25	86,75	62	70	59	68	55	66	53	64	49	62	45	61	43	58	24	56	28	54	32	48
90	88,25	91,75	67	75	64	73	60	71	58	69	54	67	50	66	48	63	42	61	28	59	32	53
95	93,25	96,75	72	80	69	78	65	76	63	74	59	72	55	71	53	68	47	66	28	64	32	58
100	98,25	101,75	77	85	74	83	70	81	68	79	64	77	60	76	58	73	52	71	48	69	32	63
110	108,25	111,75			84	93	80	91	78	89	74	87	70	86	68	83	62	81	58	79	32	73
120	118,25	121,75			94	103	90	101	88	99	84	97	80	96	78	93	72	91	68	89	58	83
130	128	132			98	113	94	111	92	109	88	107	84	106	82	103	76	101	72	98	62	93
140	138	142			108	123	104	121	102	119	98	117	94	116	92	113	86	111	82	108	72	103
150	148	152			118	133	114	131	112	129	108	127	104	126	102	123	96	121	92	118	82	113
160	156	164			128	141	124	139	122	137	118	135	114	134	112	131	106	129	102	126	92	121
170	166	174													122	141	116	139	112	136	102	131

Thread (<i>d</i>)			M12	(M14)	M16	(M18)	M20	M22	M24	M27	M30	M36										
<i>l</i>			Σt_{\min} and Σt_{\max}																			
nom.	min.	max.	min.	max.	min.	max.	min.	max.	min.	max.	min.	max.	min.	max.	min.	max.	min.	max.	min.	max.	min.	max.
180	176	184													132	151	126	149	122	146	112	141
190	186	194													142	161	136	159	132	156	122	151
200	196	204													152	171	146	169	142	166	132	161

For the calculation of the clamp lengths Σt the following formulae have been used: Bolting assemblies with either one washer or two washers

$$\Sigma t_{\max} = l_{\min} - m_{\max} - 1P$$

$$\Sigma t_{\min} \text{ (fully threaded bolts)} = a_{\max} + 4P$$

$$\Sigma t_{\min} \text{ (partially threaded bolts)} = l_{g,\max} + 4P$$

where

Σt clamp length given as the total thickness of the clamped parts between the nut bearing face and the bolt bearing face, (mm);

m height of the nut, (mm);

l length of the bolt, (mm);

P thread pitch, (mm);

a distance from the bolt bearing face to the first form (full profile) thread, (mm);

l_g distance from the bolt bearing face to the first full form (full profile) thread, (mm).

A.2 Grip lengths for bolting assemblies with one or two washers

Bolting assemblies with one washer, see Figure A.2 and Table A.2.

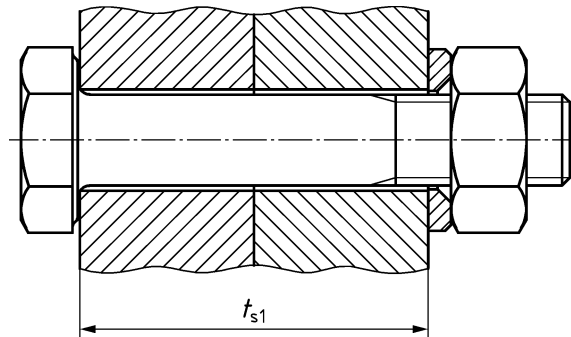

Figure A.2 — Grip Length with one washer t_{s1}

Table A.2 — Grip lengths with one washer t_{s1}

Dimensions in millimetres

Thread (d)			M12	(M14)	M16	(M18)	M20	M22	M24	M27	M30	M36											
l			$t_{s1,min}$ and $t_{s1,max}$																				
nom.	min.	max.	min.	max.	min.	max.	min.	max.	min.	max.	min.	max.	min.	max.	min.	max.	min.	max.	min.	max.	min.	max.	
35	33,75	36,25	12	17																			
40	38,75	41,25	12	22			13	17															
45	43,75	46,25	20	27			13	22															
50	48,75	51,25	25	32	14	30	13	27			17	23	17	22									
55	53,5	56,5	30	37	27	35	13	32			17	28	17	27									
60	58,5	61,5	35	42	32	40	27	37	17	35	17	33	17	32	21	29	20	26					
65	63,5	66,5	40	47	37	45	32	42	30	40	17	38	17	37	21	34	20	31					
70	68,5	71,5	45	52	42	50	37	47	35	45	31	43	17	42	21	39	20	36	24	33			
75	73,5	76,5	50	57	47	55	42	52	40	50	36	48	32	47	21	44	20	41	24	38			
80	78,5	81,5	55	62	52	60	47	57	45	55	41	53	37	52	21	49	20	46	24	43			
85	83,25	86,75	60	67	57	65	52	62	50	60	46	58	42	57	40	54	20	50	24	48	27	41	
90	88,25	91,75	65	72	62	70	57	67	55	65	51	63	47	62	45	59	38	55	24	53	27	46	
95	93,25	96,75	70	77	67	75	62	72	60	70	56	68	52	67	50	64	43	60	24	58	27	51	
100	98,25	101,75	75	82	72	80	67	77	65	75	61	73	57	72	55	69	48	65	44	63	27	56	
110	108,25	111,75			82	90	77	87	75	85	71	83	67	82	65	79	58	75	54	73	27	66	
120	118,25	121,75			92	100	87	97	85	95	81	93	77	92	75	89	68	85	64	83	53	76	
130	128	132			96	109	91	106	89	105	85	103	81	101	79	99	72	95	68	93	57	86	
140	138	142			106	119	101	116	99	115	95	113	91	111	89	109	82	105	78	103	67	96	
150	148	152			116	129	111	126	109	125	105	123	101	121	99	119	92	115	88	113	77	106	
160	156	164			126	137	121	134	119	133	115	131	111	129	109	127	102	123	98	121	87	114	
170	166	174														119	137	112	133	108	131	97	124

EN 14399-3:2015 (E)

Thread (<i>d</i>)			M12		(M14)		M16		(M18)		M20		M22		M24		M27		M30		M36		
<i>l</i>			<i>t_{s1,min}</i> and <i>t_{s1,max}</i>																				
nom.	min.	max.	min.	max.	min.	max.	min.	max.	min.	max.	min.	max.	min.	max.	min.	max.	min.	max.	min.	max.	min.	max.	
180	176	184														129	147	122	143	118	141	107	134
190	186	194														139	157	132	153	128	151	117	144
200	196	204														149	167	142	163	138	161	127	154

For the calculation of the grip lengths t_{s1} the following formulae have been used:

$$t_{s1,max} = l_{min} - m_{max} - h_{max} - 1P$$

$$t_{s1,min} = l_{g,max} + 4P - h_{min}$$

where

t_{s1} grip length given as the total thickness of the clamped parts between the nut bearing face and the bolt bearing faceless the thickness of the washer, (mm);

l length of the bolt, (mm);

m height of the nut, (mm);

h washer thickness, (mm);

P thread pitch, (mm);

l_g distance from the bolt bearing face to the first full form (full profile) thread. For fully threaded bolts $l_{g,max}$ has the ' a' '_{max} value for product grade C screws from ISO 3508 (mm).

Bolting assemblies with two washers, see Figure A.3 and Table A.3.

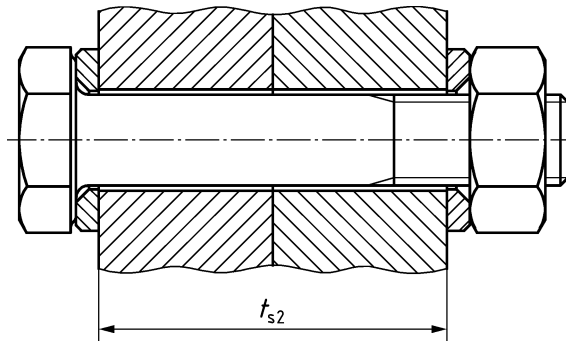

Figure A.3 — Grip Length with two washers t_{s2}

Table A.3 — Grip lengths with two washers t_{s2}

Dimensions in millimetres

Thread (<i>d</i>)			M12		(M14)		M16		(M18)		M20		M22		M24		M27		M30		M36	
<i>l</i>			$t_{s2,min}$ and $t_{s2,max}$																			
nom.	min.	max.	min.	max.	min.	max.	min.	max.	min.	max.	min.	max.	min.	max.	min.	max.	min.	max.	min.	max.	min.	max.
35	33,75	36,25	9	14																		
40	38,75	41,25	9	19			9	13														
45	43,75	46,25	17	24			9	18														
50	48,75	51,25	22	29	11	27	9	23			13	19	13	18								
55	53,5	56,5	27	34	24	32	9	28			13	24	13	23								
60	58,5	61,5	32	39	29	37	23	33	13	31	13	29	13	28	17	25	16	20				
65	63,5	66,5	37	44	34	42	28	38	26	36	13	34	13	33	17	30	16	25				
70	68,5	71,5	42	49	39	47	33	43	31	41	27	39	13	38	17	35	16	30	20	28		
75	73,5	76,5	47	54	44	52	38	48	36	46	32	44	28	43	17	40	16	35	20	33		
80	78,5	81,5	52	59	49	57	43	53	41	51	37	49	33	48	17	45	16	40	20	38		
85	83,25	86,75	57	64	54	61	48	57	46	56	42	54	38	52	36	50	16	45	20	42	22	35
90	88,25	91,75	62	69	59	66	53	62	51	61	47	59	43	57	41	55	34	50	20	47	22	40
95	93,25	96,75	67	74	64	71	58	67	56	66	52	64	48	62	46	60	39	55	20	52	22	45
100	98,25	101,75	72	79	69	76	63	72	61	71	57	69	53	67	51	65	44	60	40	57	22	50
110	108,25	111,75			79	86	73	82	71	81	67	79	63	77	61	75	54	70	50	67	22	60
120	118,25	121,75			89	96	83	92	81	91	77	89	73	87	71	85	64	80	60	77	48	70
130	128	132			93	106	87	102	85	101	81	98	77	97	75	94	68	90	64	87	52	79
140	138	142			103	116	97	112	95	111	91	108	87	107	85	104	78	100	74	97	62	89
150	148	152			113	126	107	122	105	121	101	118	97	117	95	114	88	110	84	107	72	99
160	156	164			123	134	117	130	115	129	111	126	107	125	105	122	98	118	94	115	82	107
170	166	174													115	132	108	128	104	125	92	117

Thread (<i>d</i>)			M12	(M14)	M16	(M18)	M20	M22	M24	M27	M30	M36										
<i>l</i>			<i>t_{s2,min}</i> and <i>t_{s2,max}</i>																			
nom.	min.	max.	min.	max.	min.	max.	min.	max.	min.	max.	min.	max.	min.	max.	min.	max.	min.	max.	min.	max.	min.	max.
180	176	184													125	142	118	138	114	135	102	127
190	186	194													135	152	128	148	124	145	112	137
200	196	204													145	162	138	158	134	155	122	147

For the calculation of the grip lengths *t_{s2}* the following formulae have been used:

$$t_{s2,max} = l_{min} - m_{max} - 2h_{max} - 1P$$

$$t_{s2,min} = l_{g,max} + 4P - 2h_{min}$$

where

t_{s2} grip length given as the total thickness of the clamped parts between the nut bearing face and the bolt bearing face less the thickness of the two washers, (mm);

l length of the bolt, (mm);

m height of the nut, (mm);

h washer thickness, (mm);

P thread pitch, (mm);

l_g distance from the bolt bearing face to the first full form (full profile) thread. For fully threaded bolts *l_{g,max}* has the '*a*'_{max} value for product grade C screws from ISO 3508 (mm).

Bibliography

- [1] EN 1090-2, *Execution of steel structures and aluminium structures - Part 2: Technical requirements for steel structures*
- [2] EN 1993-1-8, *Eurocode 3: Design of steel structures - Part 1-8: Design of joints*
- [3] EN 14399-4, *High-strength structural bolting assemblies for preloading - Part 4: System HV - Hexagon bolt and nut assemblies*
- [4] EN 14399-7, *High-strength structural bolting assemblies for preloading - Part 7: System HR - Countersunk head bolt and nut assemblies*
- [5] EN 14399-8, *High-strength structural bolting assemblies for preloading - Part 8: System HV - Hexagon fit bolt and nut assemblies*
- [6] EN 14399-9, *High-strength structural bolting assemblies for preloading - Part 9: System HR or HV - Direct tension indicators for bolt and nut assemblies*
- [7] EN 14399-10, *High-strength structural bolting assemblies for preloading - Part 10: System HRC - Bolt and nut assemblies with calibrated preload*
- [8] EN ISO 4032, *Hexagon regular nuts (style 1) - Product grades A and B (ISO 4032)*
- [9] ISO 272, *Fasteners - Hexagon products - Widths across flats*
- [10] ISO 888, *Fasteners - Bolts, screws and studs - Nominal lengths and thread lengths*

British Standards Institution (BSI)

BSI is the national body responsible for preparing British Standards and other standards-related publications, information and services.

BSI is incorporated by Royal Charter. British Standards and other standardization products are published by BSI Standards Limited.

About us

We bring together business, industry, government, consumers, innovators and others to shape their combined experience and expertise into standards-based solutions.

The knowledge embodied in our standards has been carefully assembled in a dependable format and refined through our open consultation process. Organizations of all sizes and across all sectors choose standards to help them achieve their goals.

Information on standards

We can provide you with the knowledge that your organization needs to succeed. Find out more about British Standards by visiting our website at bsigroup.com/standards or contacting our Customer Services team or Knowledge Centre.

Buying standards

You can buy and download PDF versions of BSI publications, including British and adopted European and international standards, through our website at bsigroup.com/shop, where hard copies can also be purchased.

If you need international and foreign standards from other Standards Development Organizations, hard copies can be ordered from our Customer Services team.

Subscriptions

Our range of subscription services are designed to make using standards easier for you. For further information on our subscription products go to bsigroup.com/subscriptions.

With **British Standards Online (BSOL)** you'll have instant access to over 55,000 British and adopted European and international standards from your desktop. It's available 24/7 and is refreshed daily so you'll always be up to date.

You can keep in touch with standards developments and receive substantial discounts on the purchase price of standards, both in single copy and subscription format, by becoming a **BSI Subscribing Member**.

PLUS is an updating service exclusive to BSI Subscribing Members. You will automatically receive the latest hard copy of your standards when they're revised or replaced.

To find out more about becoming a BSI Subscribing Member and the benefits of membership, please visit bsigroup.com/shop.

With a **Multi-User Network Licence (MUNL)** you are able to host standards publications on your intranet. Licences can cover as few or as many users as you wish. With updates supplied as soon as they're available, you can be sure your documentation is current. For further information, email bsmusales@bsigroup.com.

BSI Group Headquarters

389 Chiswick High Road London W4 4AL UK

Revisions

Our British Standards and other publications are updated by amendment or revision.

We continually improve the quality of our products and services to benefit your business. If you find an inaccuracy or ambiguity within a British Standard or other BSI publication please inform the Knowledge Centre.

Copyright

All the data, software and documentation set out in all British Standards and other BSI publications are the property of and copyrighted by BSI, or some person or entity that owns copyright in the information used (such as the international standardization bodies) and has formally licensed such information to BSI for commercial publication and use. Except as permitted under the Copyright, Designs and Patents Act 1988 no extract may be reproduced, stored in a retrieval system or transmitted in any form or by any means – electronic, photocopying, recording or otherwise – without prior written permission from BSI. Details and advice can be obtained from the Copyright & Licensing Department.

Useful Contacts:

Customer Services

Tel: +44 845 086 9001

Email (orders): orders@bsigroup.com

Email (enquiries): cservices@bsigroup.com

Subscriptions

Tel: +44 845 086 9001

Email: subscriptions@bsigroup.com

Knowledge Centre

Tel: +44 20 8996 7004

Email: knowledgecentre@bsigroup.com

Copyright & Licensing

Tel: +44 20 8996 7070

Email: copyright@bsigroup.com



...making excellence a habit.™