

INTERNATIONAL
STANDARD

ISO
10642

Second edition
2004-03-01

**Hexagon socket countersunk head
screws**

Vis à tête fraisée à six pans creux



Reference number
ISO 10642:2004(E)

© ISO 2004

PDF disclaimer

This PDF file may contain embedded typefaces. In accordance with Adobe's licensing policy, this file may be printed or viewed but shall not be edited unless the typefaces which are embedded are licensed to and installed on the computer performing the editing. In downloading this file, parties accept therein the responsibility of not infringing Adobe's licensing policy. The ISO Central Secretariat accepts no liability in this area.

Adobe is a trademark of Adobe Systems Incorporated.

Details of the software products used to create this PDF file can be found in the General Info relative to the file; the PDF-creation parameters were optimized for printing. Every care has been taken to ensure that the file is suitable for use by ISO member bodies. In the unlikely event that a problem relating to it is found, please inform the Central Secretariat at the address given below.

© ISO 2004

All rights reserved. Unless otherwise specified, no part of this publication may be reproduced or utilized in any form or by any means, electronic or mechanical, including photocopying and microfilm, without permission in writing from either ISO at the address below or ISO's member body in the country of the requester.

ISO copyright office
Case postale 56 • CH-1211 Geneva 20
Tel. + 41 22 749 01 11
Fax + 41 22 749 09 47
E-mail copyright@iso.org
Web www.iso.org

Published in Switzerland

Contents

	Page
1 Scope	1
2 Normative references	1
3 Dimensions and gauging of head	2
4 Requirements and reference International Standards	6
5 Designation	7

Foreword

ISO (the International Organization for Standardization) is a worldwide federation of national standards bodies (ISO member bodies). The work of preparing International Standards is normally carried out through ISO technical committees. Each member body interested in a subject for which a technical committee has been established has the right to be represented on that committee. International organizations, governmental and non-governmental, in liaison with ISO, also take part in the work. ISO collaborates closely with the International Electrotechnical Commission (IEC) on all matters of electrotechnical standardization.

International Standards are drafted in accordance with the rules given in the ISO/IEC Directives, Part 2.

The main task of technical committees is to prepare International Standards. Draft International Standards adopted by the technical committees are circulated to the member bodies for voting. Publication as an International Standard requires approval by at least 75 % of the member bodies casting a vote.

Attention is drawn to the possibility that some of the elements of this document may be the subject of patent rights. ISO shall not be held responsible for identifying any or all such patent rights.

ISO 10642 was prepared by Technical Committee ISO/TC 2, *Fasteners*.

This second edition cancels and replaces the first edition (ISO 10642:1997), which has been technically revised.

Hexagon socket countersunk head screws

1 Scope

This International Standard specifies the characteristics of hexagon socket countersunk head screws with threads from M3 up to and including M20, with product grade A and property classes 8.8, 10.9 and 12.9.

NOTE Particular attention is drawn to the note in Table 2 and to Table 3, concerning the limitation on ultimate tensile load.

If, in special cases, specifications other than those listed in this International Standard are required, they should be selected from existing International Standards, e.g. ISO 261, ISO 888, ISO 898-1, ISO 965-2 and ISO 4759-1.

2 Normative references

The following referenced documents are indispensable for the application of this document. For dated references, only the edition cited applies. For undated references, the latest edition of the referenced document (including any amendments) applies.

ISO 225, *Fasteners — Bolts, screws, studs and nuts — Symbols and designations of dimensions*

ISO 261, *ISO general-purpose metric screw threads — General plan*

ISO 888, *Bolts, screws and studs — Nominal lengths, and thread lengths for general purpose bolts*

ISO 898-1, *Mechanical properties of fasteners made of carbon steel and alloy steel — Part 1: Bolts, screws and studs*

ISO 965-2, *ISO general purpose metric screw threads — Tolerances — Part 2: Limits of sizes for general purpose external and internal screw threads — Medium quality*

ISO 965-3, *ISO general purpose metric screw threads — Tolerances — Part 3: Deviations for constructional screw threads*

ISO 3269, *Fasteners — Acceptance inspection*

ISO 4042, *Fasteners — Electroplated coatings*

ISO 4753, *Fasteners — Ends of parts with external ISO metric thread*

ISO 4759-1, *Tolerances for fasteners — Part 1: Bolts, screws, studs and nuts — Product grades A, B and C*

ISO 6157-1, *Fasteners — Surface discontinuities — Part 1: Bolts, screws and studs for general requirements*

ISO 6157-3, *Fasteners — Surface discontinuities — Part 3: Bolts, screws and studs for special requirements*

ISO 8992, *Fasteners — General requirements for bolts, screws, studs and nuts*

ISO 10683, *Fasteners — Non-electrolytically applied zinc flake coatings*

ISO 23429, *Gauging of hexagon sockets*

3 Dimensions and gauging of head

3.1 Dimensions

See Figure 1 and Table 1.

Symbols and designations of dimensions are defined in ISO 225.

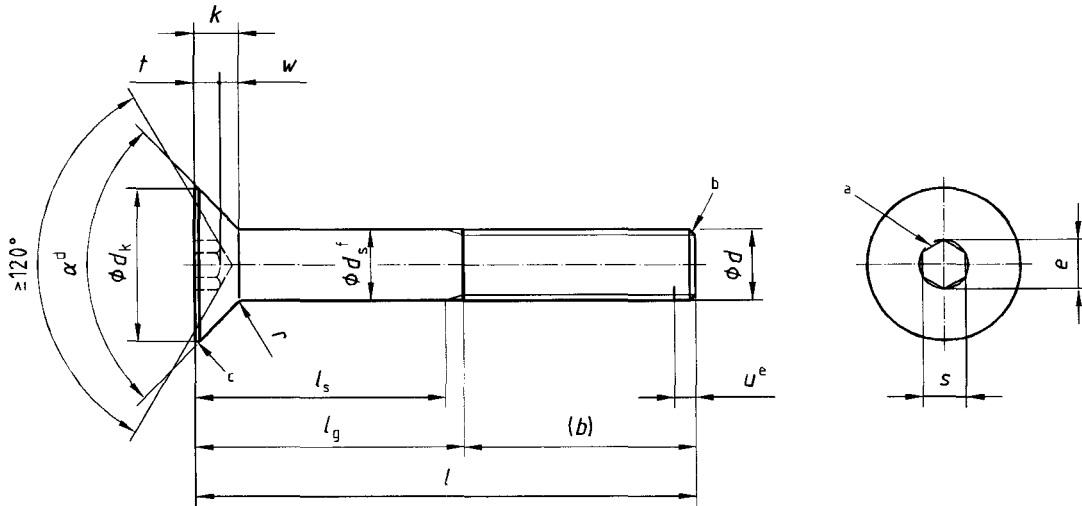

Permissible alternative form of socket

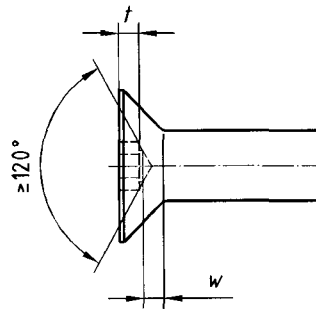
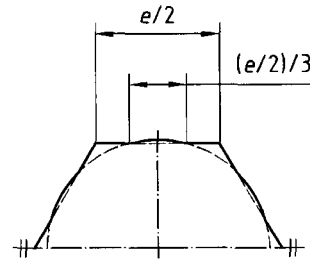

Figure 1 — Hexagon socket countersunk head screws

For broached sockets which are at the maximum limit of size the overcut resulting from drilling shall not exceed 1/3 of the length of any flat of the socket which is $e/2$.



- a A slight rounding or countersink at the mouth of the socket is permissible.
- b Point to be chamfered or, for sizes M4 and below, "as rolled" in accordance with ISO 4753.
- c Edge of the head to be truncated or rounded.
- d $\alpha = 90^\circ$ à 92° .
- e Incomplete thread $u \leq 2 P$.
- f d_s applies if values of $l_{s, \min}$ are specified.

Figure 1 — Hexagon socket countersunk head screws (continued)

3.2 Gauging of head

See Figure 2.

The top surface of the screw shall be located between the gauge surfaces A and B.

Tolerances in millimetres

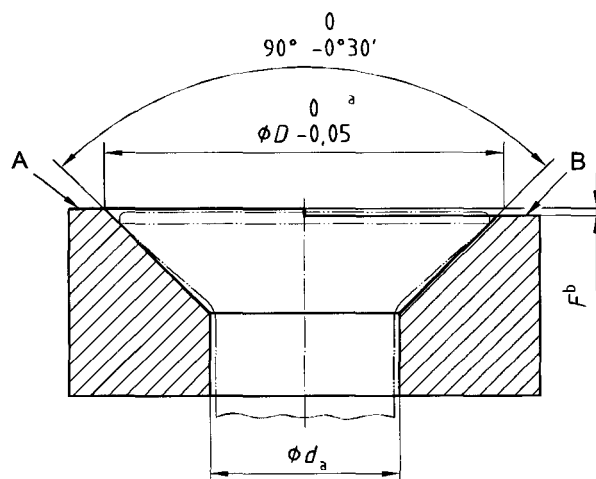

- a $D = d_{k, \text{theor., max}}$ (see Table 1).
- b F^p is the Flushness tolerance of the head (see Table 1).

Figure 2 — Flushness gauge

Table 1 — Dimensions

Dimensions in millimetres

Thread (<i>d</i>)		M3	M4	M5	M6	M8	M10	M12	(M14) ⁹	M16	M20										
<i>p</i> ^a		0,5	0,7	0,8	1	1,25	1,5	1,75	2	2	2,5										
<i>b</i> ^b	ref.	18	20	22	24	28	32	36	40	44	52										
<i>d_a</i>	max.	3,3	4,4	5,5	6,6	8,54	10,62	13,5	15,5	17,5	22										
<i>d_k</i>	theor. max.	6,72	8,96	11,20	13,44	17,92	22,40	26,88	30,8	33,60	40,32										
	actual min.	5,54	7,53	9,43	11,34	15,24	19,22	23,12	26,52	29,01	36,05										
<i>d_s</i>	max.	3,00	4,00	5,00	6,00	8,00	10,00	12,00	14,00	16,00	20,00										
	min.	2,86	3,82	4,82	5,82	7,78	9,78	11,73	13,73	15,73	19,67										
<i>e^{c, d}</i>	min.	2,303	2,873	3,443	4,583	5,723	6,863	9,149	11,429	11,429	13,716										
<i>k</i>	max.	1,86	2,48	3,1	3,72	4,96	6,2	7,44	8,4	8,8	10,16										
<i>h^e</i>	max.	0,25	0,25	0,3	0,35	0,4	0,4	0,45	0,5	0,6	0,75										
<i>r</i>	min.	0,1	0,2	0,2	0,25	0,4	0,4	0,6	0,6	0,6	0,8										
<i>s^d</i>	nom.	2	2,5	3	4	5	6	8	10	10	12										
	max.	2,08	2,58	3,08	4,095	5,14	6,140	8,175	10,175	10,175	12,212										
	min.	2,02	2,52	3,02	4,020	5,02	6,020	8,025	10,025	10,025	12,032										
<i>t</i>	min.	1,1	1,5	1,9	2,2	3	3,6	4,3	4,5	4,8	5,6										
<i>w</i>	min.	0,25	0,45	0,66	0,7	1,16	1,62	1,8	1,62	2,2	2,2										
<i>l^f</i>		Shank length <i>l_s</i> and grip length <i>l_g</i>																			
		<i>l_s</i> min.	<i>l_g</i> max.	<i>l_s</i> min.	<i>l_g</i> max.	<i>l_s</i> min.	<i>l_g</i> max.	<i>l_s</i> min.	<i>l_g</i> max.	<i>l_s</i> min.	<i>l_g</i> max.	<i>l_s</i> min.	<i>l_g</i> max.	<i>l_s</i> min.	<i>l_g</i> max.	<i>l_s</i> min.	<i>l_g</i> max.	<i>l_s</i> min.	<i>l_g</i> max.	<i>l_s</i> min.	<i>l_g</i> max.
nom.	min.	max.																			
8	7,71	8,29																			
10	9,71	10,29																			
12	11,65	12,35																			
16	15,65	16,35																			
20	19,58	20,42																			
25	24,58	25,42																			
30	29,58	30,42	9,5	12	6,5	10															
35	34,5	35,5			11,5	15	9	13													
40	39,5	40,5			16,5	20	14	18	11	16											
45	44,5	45,5					19	23	16	21											
50	49,5	50,5					24	28	21	26	15,75	22									
55	54,4	55,6							26	31	20,75	27	15,5	23							

Table 1 — Dimensions (continued)

60	59,4	60,6							31	36	25,75	32	20,5	28								
65	64,4	65,6									30,75	37	25,5	33	20,25	29						
70	69,4	70,6									35,75	42	30,5	38	25,25	34	20	30				
80	79,4	80,6									45,75	52	40,5	48	35,25	44	30	40	26	36		
90	89,3	90,7											50,5	58	45,25	54	40	50	36	46		
100	99,3	100,7											60,5	68	55,25	64	50	60	46	56	35,5	48

^a P is the pitch of the thread.

^b For lengths between the bold stepped lines in the unshaded area.

^c $e_{min} = 1,14 s_{min}$.

^d Combined gauging of socket dimensions e and s , see ISO 23429.

^e H' is the flushness of the head, see Figure 2. The gauge dimension H' has the tolerance $\begin{matrix} 0 \\ -0,01 \end{matrix}$.

^f The range of commercial lengths is between the bold stepped lines. Lengths in the shaded area are threaded to the head within $3 P$. Lengths below the shaded area have values of l_g and l_s in accordance with the following formulae:

$$l_{g, \max} = l_{nom} - b$$

$$l_{s, \min} = l_{g, \max} - 5 P$$

^g The size in brackets should be avoided if possible.

4 Requirements and reference International Standards

See Tables 2 and 3.

Table 2 — Requirements and reference International Standards

Material		Steel
General requirements	International Standard	ISO 8992
Thread	Tolerance	6g for property classes 8.8 and 10.9; 5g6g for property class 12.9
	International Standards	ISO 261, ISO 965-2, ISO 965-3
Mechanical properties	Property class ^a	8.8, 10.9, 12.9
	International Standard	ISO 898-1
Tolerances	Product grade	A
	International Standard	ISO 4759-1
Finish		As processed. Requirements for electroplating are covered in ISO 4042. Requirements for non-electrolytically applied zinc flake coatings are covered in ISO 10683.
Surface discontinuities		Limits for surface discontinuities are given in ISO 6157-1 and ISO 6157-3 for property class 12.9.
Acceptability		Acceptance procedure is covered in ISO 3269.

^a Because of their head configurations, these screws may not meet the minimum ultimate tensile load for property classes 8.8, 10.9 and 12.9, specified in ISO 898-1, when tested in accordance with test programme B. They shall nevertheless meet the other material and property requirements for property classes 8.8, 10.9 and 12.9 specified in ISO 898-1. In addition, when full-size screws are loaded with the head supported on a suitable collar (conical bearing surface) using the type of testing fixture illustrated in ISO 898-1, they shall withstand, without fracture, the minimum ultimate tensile loads given in Table 3. If tested to failure, the fracture may occur in the threaded section, the head, the shank or at the head/shank junction.

**Table 3 — Minimum ultimate tensile loads for hexagon socket countersunk head screws
(80 % of the values specified in ISO 898-1)**

Thread (<i>d</i>)	Property class		
	8.8	10.9	12.9
	Minimum ultimate tensile load N		
M3	3 220	4 180	4 190
M4	5 620	7 300	8 560
M5	9 080	11 800	13 800
M6	12 900	16 700	19 600
M8	23 400	30 500	35 700
M10	37 100	48 200	56 600
M12	53 900	70 200	82 400
M14	73 600	96 000	112 000
M16	100 000	130 000	154 000
M20	162 000	204 000	239 000

5 Designation

EXAMPLE A hexagon socket countersunk head screw with thread M12 nominal length $l = 40$ mm and property class 12.9 is designated as follows:

Hexagon socket countersunk head screw ISO 10642-M12×40-12.9

ISO 10642:2004(E)

ICS 21.060.10

Price based on 7 pages

© ISO 2004 – All rights reserved