

---

---

## Hexalobular socket cheese head screws

*Vis à métaux à tête cylindrique basse à six lobes internes*

www.iso.org



Reference number  
ISO 14580:2011(E)

© ISO 2011

**PDF disclaimer**

This PDF file may contain embedded typefaces. In accordance with Adobe's licensing policy, this file may be printed or viewed but shall not be edited unless the typefaces which are embedded are licensed to and installed on the computer performing the editing. In downloading this file, parties accept therein the responsibility of not infringing Adobe's licensing policy. The ISO Central Secretariat accepts no liability in this area.

Adobe is a trademark of Adobe Systems Incorporated.

Details of the software products used to create this PDF file can be found in the General Info relative to the file; the PDF-creation parameters were optimized for printing. Every care has been taken to ensure that the file is suitable for use by ISO member bodies. In the unlikely event that a problem relating to it is found, please inform the Central Secretariat at the address given below.



**COPYRIGHT PROTECTED DOCUMENT**

© ISO 2011

All rights reserved. Unless otherwise specified, no part of this publication may be reproduced or utilized in any form or by any means, electronic or mechanical, including photocopying and microfilm, without permission in writing from either ISO at the address below or ISO's member body in the country of the requester.

ISO copyright office  
Case postale 56 • CH-1211 Geneva 20  
Tel. + 41 22 749 01 11  
Fax + 41 22 749 09 47  
E-mail [copyright@iso.org](mailto:copyright@iso.org)  
Web [www.iso.org](http://www.iso.org)

Published in Switzerland

## Foreword

ISO (the International Organization for Standardization) is a worldwide federation of national standards bodies (ISO member bodies). The work of preparing International Standards is normally carried out through ISO technical committees. Each member body interested in a subject for which a technical committee has been established has the right to be represented on that committee. International organizations, governmental and non-governmental, in liaison with ISO, also take part in the work. ISO collaborates closely with the International Electrotechnical Commission (IEC) on all matters of electrotechnical standardization.

International Standards are drafted in accordance with the rules given in the ISO/IEC Directives, Part 2.

The main task of technical committees is to prepare International Standards. Draft International Standards adopted by the technical committees are circulated to the member bodies for voting. Publication as an International Standard requires approval by at least 75 % of the member bodies casting a vote.

Attention is drawn to the possibility that some of the elements of this document may be the subject of patent rights. ISO shall not be held responsible for identifying any or all such patent rights.

ISO 14580 was prepared by Technical Committee ISO/TC 2, *Fasteners*, Subcommittee SC 10, *Product standards for fasteners*.

This second edition cancels and replaces the first edition (ISO 14580:2001), of which it constitutes a minor revision. It also incorporates the Technical Corrigendum ISO 14580:2001/Cor.1:2004.

© ISO 2015

# Hexalobular socket cheese head screws

## 1 Scope

This International Standard specifies the characteristics of hexalobular socket cheese head screws of product grade A and with thread sizes from M2 up to and including M10.

If, in special cases, specifications other than those listed in this International Standard are required, they can be selected from existing International Standards, for example ISO 261, ISO 888, ISO 898-1, ISO 965-2, ISO 3506-1 and ISO 4759-1.

## 2 Normative references

The following referenced documents are indispensable for the application of this document. For dated references, only the edition cited applies. For undated references, the latest edition of the referenced document (including any amendments) applies.

ISO 225, *Fasteners — Bolts, screws, studs and nuts — Symbols and descriptions of dimensions*

ISO 261, *ISO general-purpose metric screw threads — General plan*

ISO 898-1, *Mechanical properties of fasteners made of carbon steel and alloy steel — Part 1: Bolts, screws and studs with specified property classes — Coarse thread and fine pitch thread*

ISO 965-2, *ISO general purpose metric screw threads — Tolerances — Part 2: Limits of sizes for general purpose external and internal screw threads — Medium quality*

ISO 1207, *Slotted cheese head screws — Product grade A*

ISO 3269, *Fasteners — Acceptance inspection*

ISO 3506-1, *Mechanical properties of corrosion-resistant stainless steel fasteners — Part 1: Bolts, screws and studs*

ISO 4042, *Fasteners — Electroplated coatings*

ISO 4759-1, *Tolerances for fasteners — Part 1: Bolts, screws, studs and nuts — Product grades A, B and C*

ISO 6157-1, *Fasteners — Surface discontinuities — Part 1: Bolts, screws and studs for general requirements*

ISO 8839, *Mechanical properties of fasteners — Bolts, screws, studs and nuts made of non-ferrous metals*

ISO 8992, *Fasteners — General requirements for bolts, screws, studs and nuts*

ISO 10664, *Hexalobular internal driving feature for bolts and screws*

ISO 10683, *Fasteners — Non-electrolytically applied zinc flake coatings*

### 3 Dimensions

See Figure 1 and Table 1.

Symbols and descriptions of dimensions are specified in ISO 225.

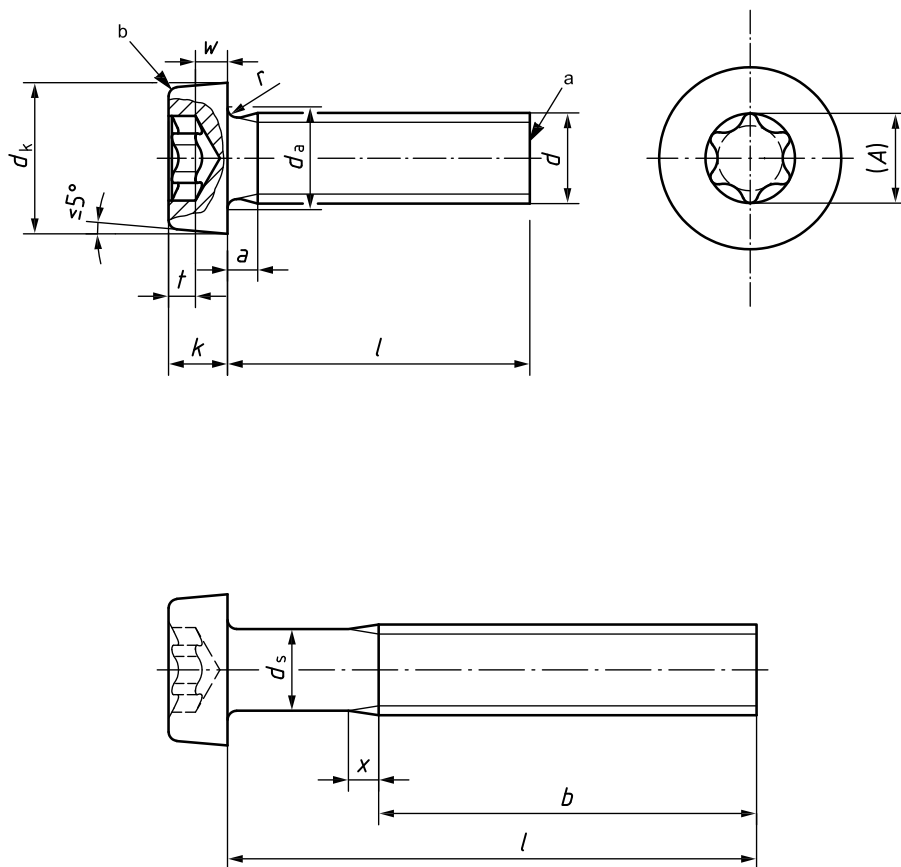

NOTE The shank diameter,  $d_s$ , is approximately equal to the pitch diameter or equal to the major thread diameter.

- a As-rolled end.
- b Edge may be rounded or flat.

Figure 1

Table 1 — Dimensions

Dimensions in millimetres

Thread, <i>d</i>	M2	M2,5	M3	(M3,5) <sup>a</sup>	M4	M5	M6	M8	M10		
<i>P</i> <sup>b</sup>	0,4	0,45	0,5	0,6	0,7	0,8	1	1,25	1,5		
<i>a</i> max.	0,8	0,9	1	1,2	1,4	1,6	2	2,5	3		
<i>b</i> min.	25	25	25	38	38	38	38	38	38		
<i>d<sub>k</sub></i>	nom. = max.	3,80	4,50	5,50	6,00	7,00	8,50	10,00	13,00	16,00	
	min.	3,62	4,32	5,32	5,82	6,78	8,28	9,78	12,73	15,73	
<i>d<sub>a</sub></i> max.	2,6	3,1	3,6	4,1	4,7	5,7	6,8	9,2	11,2		
<i>k<sup>c</sup></i>	nom. = max.	1,55	1,85	2,40	2,60	3,10	3,65	4,40	5,80	6,90	
	min.	1,41	1,71	2,26	2,46	2,92	3,47	4,10	5,50	6,54	
<i>r</i> min.	0,1	0,1	0,1	0,1	0,2	0,2	0,25	0,4	0,4		
<i>w</i> min.	0,5	0,7	0,75	1,0	1,1	1,3	1,6	2	2,4		
<i>x</i> max.	1,0	1,1	1,25	1,50	1,75	2,0	2,5	3,2	3,8		
Hexalobular socket <sup>d</sup>	Socket no.	<b>6</b>	<b>8</b>	<b>10</b>	<b>15</b>	<b>20</b>	<b>25</b>	<b>30</b>	<b>45</b>	<b>50</b>	
	<i>A</i> ref.	1,75	2,4	2,8	3,35	3,95	4,5	5,6	7,95	8,95	
	max.	0,84	0,91	1,27	1,33	1,66	1,91	2,29	3,05	3,43	
	<i>t</i> min.	0,71	0,78	1,01	1,07	1,27	1,52	1,90	2,66	3,04	
<i>l<sup>e</sup></i>			Approximate mass of carbon steel screws, in kilograms per 1 000 pieces ( $\rho = 7,85 \text{ kg/dm}^3$ )								
nom. <sup>a</sup>	min.	max.									
<b>3</b>	2,8	3,2	0,160	0,272							
<b>4</b>	3,76	4,24	0,179	0,302	0,515						
<b>5</b>	4,76	5,24	0,198	0,332	0,560	0,786	1,09				
<b>6</b>	5,76	6,24	0,217	0,362	0,604	0,845	1,17	2,06			
<b>8</b>	7,71	8,29	0,254	0,422	0,692	0,966	1,33	2,30	3,56		
<b>10</b>	9,71	10,29	0,291	0,482	0,780	1,08	1,47	2,55	3,92	7,85	
<b>12</b>	11,65	12,35	0,329	0,542	0,868	1,20	1,63	2,80	4,27	8,49	14,6
<b>(14)</b>	13,65	14,35	0,365	0,602	0,956	1,32	1,79	3,05	4,62	9,13	15,6
<b>16</b>	15,65	16,35	0,402	0,662	1,04	1,44	1,95	3,30	4,98	9,77	16,6
<b>20</b>	19,58	20,42	0,478	0,782	1,22	1,68	2,25	3,78	5,69	11,0	18,6
<b>25</b>	24,58	25,42		0,932	1,44	1,98	2,64	4,40	6,56	12,6	21,1
<b>30</b>	29,58	30,42			1,66	2,28	3,02	5,02	7,45	14,2	23,6
<b>35</b>	34,5	35,5				2,57	3,41	5,62	8,25	15,8	26,1
<b>40</b>	39,5	40,5					3,80	6,25	9,20	17,4	28,6
<b>45</b>	44,5	45,5						6,88	10,0	18,9	31,1
<b>50</b>	49,5	50,5						7,50	10,9	20,6	33,6
<b>(55)</b>	54,4	55,6							11,8	22,1	36,1
<b>60</b>	59,4	60,6							12,7	23,7	38,6
<b>(65)</b>	64,4	65,6								25,2	41,1
<b>70</b>	69,4	70,6								26,8	43,6
<b>(75)</b>	74,4	75,6								28,3	46,1
<b>80</b>	79,4	80,6								29,8	48,6
NOTE Preferred lengths are the ones between the solid, bold, stepped lines.											
<sup>a</sup> Sizes in parentheses should be avoided, if possible.											
<sup>b</sup> <i>P</i> is the pitch of the thread.											
<sup>c</sup> The head height is increased against the screws, in accordance with ISO 1207, in order to improve the head strength.											
<sup>d</sup> For the acceptance of the hexalobular socket and for gauges, see ISO 10664.											
<sup>e</sup> Screws with nominal lengths above the discontinuous, stepped line are threaded up to the head ( $b = l - a$ ).											

## 4 Specifications and reference International Standards

See Table 2.

**Table 2 — Specifications and reference International Standards**

<b>Material</b>		Steel	Stainless steel	Non-ferrous metal
<b>General requirements</b>	International Standard	ISO 8992		
<b>Thread</b>	Tolerance class	6g		
	International Standard	ISO 261, ISO 965-2		
<b>Mechanical property</b>	Property class	4.8, 5.8	A2-50, A2-70 A3-50, A3-70	As agreed
	International Standard	ISO 898-1	ISO 3506-1	ISO 8839
<b>Tolerance</b>	Product grade	A		
	International Standard	ISO 4759-1		
<b>Hexalobular socket</b>	International Standard	ISO 10664		
<b>Finish — Coating</b>		As processed Requirements for electroplating are specified in ISO 4042.  Requirements for non-electrolytically applied zinc flake coatings are specified in ISO 10683.	As processed	As processed Requirements for electroplating are specified in ISO 4042.
		Additional requirements or other finishes or coatings shall be agreed between the supplier and the purchaser.		
<b>Surface integrity</b>		Limits for surface discontinuities are specified in ISO 6157-1.	—	—
<b>Acceptability</b>		Acceptance inspection is specified in ISO 3269.		

## 5 Designation

**EXAMPLE** A hexalobular socket cheese head screw with thread M5, nominal length  $l = 20$  mm and property class 4.8 is designated as follows:

**Hexalobular socket cheese head screw ISO 14580 - M5 × 20 - 4.8**



## Bibliography

- [1] ISO 888, *Bolts, screws and studs — Nominal lengths, and thread lengths for general purpose bolts*

---

---

**ICS 21.060.10**

Price based on 5 pages