

BS EN ISO 2320:2015



BSI Standards Publication

Fasteners — Prevailing torque steel nuts — Functional properties

bsi.

...making excellence a habit.™

National foreword

This British Standard is the UK implementation of EN ISO 2320:2015. It supersedes BS EN ISO 2320:2008 which is withdrawn.

The UK participation in its preparation was entrusted to Technical Committee FME/9, Fasteners.

A list of organizations represented on this committee can be obtained on request to its secretary.

This publication does not purport to include all the necessary provisions of a contract. Users are responsible for its correct application.

© The British Standards Institution 2016.
Published by BSI Standards Limited 2016

ISBN 978 0 580 86178 9

ICS 21.060.20

Compliance with a British Standard cannot confer immunity from legal obligations.

This British Standard was published under the authority of the Standards Policy and Strategy Committee on 31 January 2016.

Amendments/corrigenda issued since publication

Date	Text affected
------	---------------

EUROPEAN STANDARD

EN ISO 2320

NORME EUROPÉENNE

EUROPÄISCHE NORM

December 2015

ICS 21.060.20

Supersedes EN ISO 2320:2008

English Version

Fasteners - Prevailing torque steel nuts - Functional properties (ISO 2320:2015)

Fixations - Écrous autofreinés en acier -
Caractéristiques fonctionnelles (ISO 2320:2015)

Mechanische Verbindungselemente - Muttern aus Stahl
mit Klemmteil - Mechanische und funktionelle
Eigenschaften (ISO 2320:2015)

This European Standard was approved by CEN on 17 October 2015.

CEN members are bound to comply with the CEN/CENELEC Internal Regulations which stipulate the conditions for giving this European Standard the status of a national standard without any alteration. Up-to-date lists and bibliographical references concerning such national standards may be obtained on application to the CEN-CENELEC Management Centre or to any CEN member.

This European Standard exists in three official versions (English, French, German). A version in any other language made by translation under the responsibility of a CEN member into its own language and notified to the CEN-CENELEC Management Centre has the same status as the official versions.

CEN members are the national standards bodies of Austria, Belgium, Bulgaria, Croatia, Cyprus, Czech Republic, Denmark, Estonia, Finland, Former Yugoslav Republic of Macedonia, France, Germany, Greece, Hungary, Iceland, Ireland, Italy, Latvia, Lithuania, Luxembourg, Malta, Netherlands, Norway, Poland, Portugal, Romania, Slovakia, Slovenia, Spain, Sweden, Switzerland, Turkey and United Kingdom.



EUROPEAN COMMITTEE FOR STANDARDIZATION
COMITÉ EUROPÉEN DE NORMALISATION
EUROPÄISCHES KOMITEE FÜR NORMUNG

CEN-CENELEC Management Centre: Avenue Marnix 17, B-1000 Brussels

European foreword

This document (EN ISO 2320:2015) has been prepared by Technical Committee ISO/TC 2 "Fasteners" in collaboration with Technical Committee CEN/TC 185 "Fasteners" the secretariat of which is held by DIN.

This European Standard shall be given the status of a national standard, either by publication of an identical text or by endorsement, at the latest by June 2016, and conflicting national standards shall be withdrawn at the latest by June 2016.

Attention is drawn to the possibility that some of the elements of this document may be the subject of patent rights. CEN [and/or CENELEC] shall not be held responsible for identifying any or all such patent rights.

This document supersedes EN ISO 2320:2008.

According to the CEN-CENELEC Internal Regulations, the national standards organizations of the following countries are bound to implement this European Standard: Austria, Belgium, Bulgaria, Croatia, Cyprus, Czech Republic, Denmark, Estonia, Finland, Former Yugoslav Republic of Macedonia, France, Germany, Greece, Hungary, Iceland, Ireland, Italy, Latvia, Lithuania, Luxembourg, Malta, Netherlands, Norway, Poland, Portugal, Romania, Slovakia, Slovenia, Spain, Sweden, Switzerland, Turkey and the United Kingdom.

Endorsement notice

The text of ISO 2320:2015 has been approved by CEN as EN ISO 2320:2015 without any modification.

Contents

Page

Foreword	iv
1 Scope	1
2 Normative references	1
3 Terms and definitions	1
4 Symbols	2
5 Thread	3
6 Lubrication	3
7 Mechanical properties of prevailing torque nuts	3
8 Functional requirements for prevailing torque properties	3
9 Test method	11
9.1 General.....	11
9.2 Proof load test.....	11
9.3 Prevailing torque test.....	11
9.3.1 General.....	11
9.3.2 Test apparatus.....	12
9.3.3 Test parts.....	12
9.3.4 Test procedure.....	13
9.3.5 Test report.....	15
Annex A (normative) Temperature influence on prevailing torques of nuts with non-metallic insert	16
Annex B (informative) Principles for the evaluation of the total coefficient of friction, μ_{tot}	17
Annex C (informative) Test clamp force and prevailing torques for prevailing torque nuts M3 and M4 in property classes 8 and 10	18
Bibliography	20

Foreword

ISO (the International Organization for Standardization) is a worldwide federation of national standards bodies (ISO member bodies). The work of preparing International Standards is normally carried out through ISO technical committees. Each member body interested in a subject for which a technical committee has been established has the right to be represented on that committee. International organizations, governmental and non-governmental, in liaison with ISO, also take part in the work. ISO collaborates closely with the International Electrotechnical Commission (IEC) on all matters of electrotechnical standardization.

The procedures used to develop this document and those intended for its further maintenance are described in the ISO/IEC Directives, Part 1. In particular the different approval criteria needed for the different types of ISO documents should be noted. This document was drafted in accordance with the editorial rules of the ISO/IEC Directives, Part 2 (see www.iso.org/directives).

Attention is drawn to the possibility that some of the elements of this document may be the subject of patent rights. ISO shall not be held responsible for identifying any or all such patent rights. Details of any patent rights identified during the development of the document will be in the Introduction and/or on the ISO list of patent declarations received (see www.iso.org/patents).

Any trade name used in this document is information given for the convenience of users and does not constitute an endorsement.

For an explanation on the meaning of ISO specific terms and expressions related to conformity assessment, as well as information about ISO's adherence to the WTO principles in the Technical Barriers to Trade (TBT) see the following URL: [Foreword - Supplementary information](#)

The committee responsible for this document is ISO/TC 2, *Fasteners*, Subcommittee SC 12, *Fasteners with metric internal thread*.

This fifth edition cancels and replaces the fourth edition (ISO 2320:2008), which has been technically revised. The following changes have been made:

- property class 9 has been deleted;
- prevailing torques for nuts M3 and M4 have been moved to [Annex C](#);
- in the test fixture, the thread protrusion through the prevailing torque feature has been changed to 3 to 5 pitches;
- the reference surface condition for the test bolt has been specified in accordance with ISO 16047 (plain surface, uncoated and degreased, unless otherwise agreed);
- the determination of the prevailing-off torque has been changed from the upper value to the minimum value (new point 5 in [Figure 2](#)), which changes the acceptance conditions;
- other editorial revisions.

Fasteners — Prevailing torque steel nuts — Functional properties

1 Scope

This International Standard specifies the functional properties for prevailing torque steel nuts when tested at an ambient temperature range of +10 °C to +35 °C. It includes a combined test method to determine the prevailing torque properties and the torque/clamp force properties at the same time.

It applies to prevailing torque all metal type nuts and prevailing torque non-metallic insert type nuts:

- with triangular ISO thread in accordance with ISO 68-1;
- with diameter/pitch combination in accordance with ISO 261 and ISO 262;
- with coarse pitch thread M5 to M39 or with fine pitch thread M8 × 1 to M39 × 3;
- with thread tolerances in accordance with ISO 965-2;
- with mechanical properties in accordance with ISO 898-2;

Prevailing torque values specified in this standard are based on laboratory test conditions.

NOTE 1 Actual prevailing torques in practical application can vary.

NOTE 2 All metal type nuts conforming to the requirements of this International Standard are used in applications ranging from -50 °C to +150 °C.

NOTE 3 Non-metallic insert type nuts conforming to the requirements of this International Standard are used in applications ranging from -50 °C to +120 °C.

WARNING — Temperatures outside the ambient temperature range can influence the functional properties (torque/clamp force and prevailing torque properties), see [Annex A](#).

2 Normative references

The following referenced documents, in whole or in part, are normatively referenced in this document and are indispensable for its application. For dated references, only the edition cited applies. For undated references, the latest edition of the referenced document (including any amendments) applies.

ISO 273, *Fasteners — Clearance holes for bolts and screws*

ISO 898-1, *Mechanical properties of fasteners made of carbon steel and alloy steel — Part 1: Bolts, screws and studs with specified property classes — Coarse thread and fine pitch thread*

ISO 898-2, *Mechanical properties of fasteners made of carbon steel and alloy steel — Part 2: Nuts with specified property classes — Coarse thread and fine pitch thread*

ISO 965-2, *ISO general purpose metric screw threads — Tolerances — Part 2: Limits of sizes for general purpose external and internal screw threads — Medium quality*

ISO 16047:2005, *Fasteners — Torque/clamp force testing*

3 Terms and definitions

For the purposes of this document, the terms and definitions given in ISO 16047 and the following apply.

3.1 prevailing torque nut
nut which is not free-running on a mating thread by virtue of a self-contained prevailing torque feature, and which provides resistance to rotation independent of clamping or compression forces

3.2 prevailing torque developed by the nut
torque necessary to rotate the nut on its mating externally threaded component and without clamp force

3.3 prevailing-on torque
torque to rotate the nut on its mating externally threaded component with the torque measured while the nut is in motion and without clamp force

3.4 prevailing-off torque
torque to rotate after backing off the nut until the removal of the clamp force in the following 360° rotation of the nut

3.5 prevailing torque all metal type nut
nut which has a one piece or a multiple piece metal construction and derives its prevailing torque characteristics from a controlled distortion of the nut thread and/or body and/or from metallic insert(s)

3.6 prevailing torque non-metallic insert type nut
nut which has a multiple piece construction and derives its prevailing torque characteristics from insert(s) of non-metallic material retained in the nut

3.7 seating point
point in the tightening process where clamp force first appears

4 Symbols

For the purpose of this International Standard, the following symbols apply together with those defined in ISO 16047.

- D nominal diameter, in millimetre
- d_4 diameter of the hole of the fixture, in millimetre
- F_P proof load, in newton
- F_{65} lower load limit for the evaluation of the coefficient of total friction at 65 % of F_P , in newton
- F_{75} upper load limit for the evaluation of the coefficient of total friction at 75 % of F_P , in newton
- F_{80} test clamp force (shut-down force for the tightening process) at 80 % of F_P , in newton
- P pitch of the thread, in millimetre
- T_{FV} prevailing-on torque, in newton metre
- T_{Fd} prevailing-off torque, in newton metre
- T_{65} lower torque limit for the evaluation of the coefficient of total friction at F_{65} , in newton metre
- T_{75} upper torque limit for the evaluation of the coefficient of total friction at F_{75} , in newton metre

T_{80} test torque corresponding to 80 % of the proof load, in newton metre (see [Tables 1 to 7](#))

μ_{tot} coefficient of total friction

5 Thread

Threads for prevailing torque nuts shall be in accordance with ISO 965-2 except for the prevailing torque feature:

- a) for prevailing torque non-metallic insert type nuts, the GO gauge shall be suitable for free installation (by hand) until it is seated against the prevailing torque feature;
- b) for prevailing torque all metal type nuts, the GO gauge shall be suitable for free installation (by hand) to one pitch at least.

6 Lubrication

At the option of the manufacturer, a lubricant may be applied to the manufacturing lot to fulfil the functional requirements.

7 Mechanical properties of prevailing torque nuts

The mechanical properties of prevailing torque nuts shall conform to ISO 898-2.

With regard to proof load, the test method specified in [9.2](#) shall apply.

8 Functional requirements for prevailing torque properties

The prevailing-on torque shall not exceed the value specified for the applicable nut in [Tables 1 to 7](#).

The prevailing-off torque shall exceed the value specified for the applicable nut in [Tables 1 to 7](#).

For delivery inspection, the first installation/removal test applies, unless otherwise agreed.

For initial type testing and in case of dispute, a 5th removal test shall also be applied unless otherwise agreed.

Prevailing torque performance decreases as a function of the number of reuses; the consumer shall take into consideration the consequences of the decreased performance before any reuse of the nut.

By request of the customer, a temperature influence test for prevailing torque non-metallic insert type nuts as specified in [Annex A](#) may be carried out.

Table 1 — Test clamp force and prevailing torques for prevailing torque nuts of property class 04

Thread <i>D</i> <i>D</i> × <i>P</i>	Test clamp force <i>F</i> ₈₀ ^a N	Clamp force for evaluation of total friction coefficient $\mu_{\text{tot}}^{\text{b}}$		Prevailing torque Nm		
		Upper limit <i>F</i> ₇₅ ^c N	Lower limit <i>F</i> ₆₅ ^d N	1 st installation <i>T</i> _{Fv,max} ^e	1 st removal <i>T</i> _{Fd,min}	5 th removal <i>T</i> _{Fd,min}
M5	4 320	4 050	3 510	1,6	0,29	0,2
M6	6 112	5 730	4 966	3	0,45	0,3
M7	8 800	8 250	7 150	4,5	0,65	0,45
M8	11 120	10 425	9 035	6	0,85	0,6
M8×1	11 920	11 175	9 685			
M10	17 600	16 500	14 300	10,5	1,5	1
M10×1,25	18 640	17 475	15 145			
M10×1	19 600	18 375	15 925			
M12	25 600	24 000	20 800	15,5	2,3	1,6
M12×1,5	26 800	25 125	21 775			
M12×1,25	28 000	26 250	22 750			
M14	34 960	32 775	28 405	24	3,3	2,3
M14×1,5	38 000	35 625	30 875			
M16	47 760	44 775	38 805	32	4,5	3
M16×1,5	50 800	47 625	41 275			
M18	58 400	54 750	47 450	42	6	4,2
M18×1,5	65 360	61 275	53 105			
M20	74 480	69 825	60 515	54	7,5	5,3
M20×1,5	82 720	77 550	67 210			
M22	92 080	86 325	74 815	68	9,5	6,5
M22×1,5	101 200	94 875	82 225			
M24	107 280	100 575	87 165	80	11,5	8
M24×2	116 720	109 425	94 835			
M27	139 520	130 800	113 360	94	13,5	10
M27×2	150 800	141 375	122 525			
M30	170 560	159 900	138 580	108	16	12
M30×2	188 800	177 000	153 400			
M33	210 960	197 775	171 405	122	18	14
M33×2	231 360	216 900	187 980			
M36	248 400	232 875	201 825	136	21	16
M36×3	262 960	246 525	213 655			
M39	296 720	278 175	241 085	150	23	18
M39×3	313 120	293 550	254 410			

NOTE The evaluation of results from the prevailing torque test by statistical process control methods (SPC) has no statistical relevance.

a The clamp force for property class 04 nuts is equal to 80 % of the proof load of property class 04 specified in ISO 898-2 for nuts with 5 mm ≤ *D* ≤ 39 mm.

b See [Annex B](#).

c The value of the upper limit of the clamp force is equal to 75 % of the proof load, see [Annex B](#).

d The value of the lower limit of the clamp force is equal to 65 % of the proof load, see [Annex B](#).

e The values of prevailing torque for first assembly apply for all metal type nuts only. For prevailing torque non-metallic insert type nuts, the maximum prevailing torques shall be 50 % of the values.

Table 2 — Test clamp force and prevailing torques for prevailing torque nuts of property class 05

Thread <i>D</i> <i>D</i> × <i>P</i>	Test clamp force F_{80}^a N	Clamp force for evaluation of total friction coefficient μ_{tot}^b		Prevailing torque Nm		
		Upper limit F_{75}^c N	Lower limit F_{65}^d N	1 st installation $T_{Fv,max}^e$	1 st removal $T_{Fd,min}$	5 th removal $T_{Fd,min}$
M5	5 680	5 325	4 615	2,1	0,35	0,24
M6	8 000	7 500	6 500	4	0,55	0,4
M7	11 600	10 875	9 425	6	0,85	0,6
M8	14 640	13 725	11 895	8	1,15	0,8
M8×1	15 680	14 700	12 740			
M10	23 200	21 750	18 850	14	2	1,4
M10×1,25	24 480	22 950	19 890			
M10×1	25 760	24 150	20 930			
M12	33 760	31 650	27 430	21	3,1	2,1
M12×1,5	35 200	33 000	28 600			
M12×1,25	36 800	34 500	29 900			
M14	46 000	43 125	37 375	31	4,4	3
M14×1,5	50 000	46 875	40 625			
M16	62 800	58 875	51 025	42	6	4,2
M16×1,5	66 800	62 625	54 275			
M18	76 800	72 000	62 400	56	8	5,5
M18×1,5	86 000	80 625	69 875			
M20	98 000	91 875	79 625	72	10,5	7
M20×1,5	108 800	102 000	88 400			
M22	121 200	113 625	98 475	90	13	9
M22×1,5	133 200	124 875	108 225			
M24	141 200	132 375	114 725	106	15	10,5
M24×2	153 600	144 000	124 800			
M27	183 600	172 125	149 175	123	17	12
M27×2	198 400	186 000	161 200			
M30	224 400	210 375	182 325	140	19	14
M30×2	248 400	232 875	201 825			
M33	277 600	260 250	225 550	160	21,5	15,5
M33×2	304 400	285 375	247 325			
M36	326 800	306 375	265 525	180	24	17,5
M36×3	346 000	324 375	281 125			
M39	390 400	366 000	317 200	200	26,5	19,5
M39×3	412 000	386 250	334 750			

NOTE The evaluation of results from the prevailing torque test by statistical process control methods (SPC) has no statistical relevance.

a The clamp force for property class 05 nuts is equal to 80 % of the proof load of property class 05 specified in ISO 898-2 for nuts with $5 \text{ mm} \leq D \leq 39 \text{ mm}$.

b See [Annex B](#).

c The value of the upper limit of the clamp force is equal to 75 % of the proof load, see [Annex B](#).

d The value of the lower limit of the clamp force is equal to 65 % of the proof load, see [Annex B](#).

e The values of prevailing torque for first assembly apply for all metal type nuts only. For prevailing torque non-metallic insert type nuts, the maximum prevailing torques shall be 50 % of the values.

Table 3 — Test clamp force and prevailing torques for prevailing torque nuts of property class 5

Thread D $D \times P$	Test clamp force F_{80}^a N	Clamp force for evaluation of total friction coefficient μ_{tot}^b		Prevailing torque Nm		
		Upper limit F_{75}^c N	Lower limit F_{65}^d N	1 st installation $T_{Fv,max}^e$	1 st removal $T_{Fd,min}$	5 th removal $T_{Fd,min}$
M5	4 320	4 050	3 510	1,6	0,29	0,2
M6	6 112	5 730	4 966	3	0,45	0,3
M7	8 800	8 250	7 150	4,5	0,65	0,45
M8	11 120	10 425	9 035	6	0,85	0,6
M8×1	11 920	11 175	9 685			
M10	17 600	16 500	14 300	10,5	1,5	1
M10×1,25	18 640	17 475	15 145			
M10×1	19 600	18 375	15 925			
M12	25 600	24 000	20 800	15,5	2,3	1,6
M12×1,5	26 800	25 125	21 775			
M12×1,25	28 000	26 250	22 750			
M14	34 960	32 775	28 405	24	3,3	2,3
M14×1,5	38 000	35 625	30 875			
M16	47 760	44 775	38 805	32	4,5	3
M16×1,5	50 800	47 625	41 275			
M18	58 400	54 750	47 450	42	6	4,2
M18×1,5	65 680	61 575	53 365			
M20	74 480	69 825	60 515	54	7,5	5,3
M20×1,5	82 400	77 250	66 950			
M22	92 000	86 250	74 750	68	9,5	6,5
M22×1,5	100 800	94 500	81 900			
M24	107 200	100 500	87 100	80	11,5	8
M24×2	116 800	109 500	94 900			
M27	113 600	106 500	92 300	94	13,5	10
M27×2	123 200	115 500	100 100			
M30	139 200	130 500	113 100	108	16	12
M30×2	153 600	144 000	124 800			
M33	172 000	161 250	139 750	122	18	14
M33×2	188 800	177 000	153 400			
M36	202 400	189 750	164 450	136	21	16
M36×3	214 400	201 000	174 200			
M39	242 400	227 250	196 950	150	23	18
M39×3	255 200	239 250	207 350			

NOTE The evaluation of results from the prevailing torque test by statistical process control methods (SPC) has no statistical relevance.

a The clamp force for property class 5 nuts is equal to 80 % of the proof load of property class 5.8 specified in ISO 898-1 for bolts

b See [Annex B](#).

c The value of the upper limit of the clamp force is equal to 75 % of the proof load, see [Annex B](#).

d The value of the lower limit of the clamp force is equal to 65 % of the proof load, see [Annex B](#).

e The values of prevailing torque for first assembly apply for all metal type nuts only. For prevailing torque non-metallic insert type nuts, the maximum prevailing torques shall be 50 % of the values.

Table 4 — Test clamp force and prevailing torques for prevailing torque nuts of property class 6

Thread <i>D</i> <i>D</i> × <i>P</i>	Test clamp force F_{80}^a N	Clamp force for evaluation of total friction coefficient μ_{tot}^b		Prevailing torque Nm		
		Upper limit F_{75}^c N	Lower limit F_{65}^d N	1 st installation $T_{Fv,max}^e$	1 st removal $T_{Fd,min}$	5 th removal $T_{Fd,min}$
M5	5 000	4 688	4 063	1,6	0,29	0,2
M6	7 072	6 630	5 746	3	0,45	0,3
M7	10 160	9 525	8 255	4,5	0,65	0,45
M8	12 880	12 075	10 465	6	0,85	0,6
M8×1	13 760	12 900	11 180			
M10	20 400	19 125	16 575	10,5	1,5	1
M10×1,25	21 520	20 175	17 485			
M10×1	22 720	21 300	18 460			
M12	29 680	27 825	24 115	15,5	2,3	1,6
M12×1,5	31 040	29 100	25 220			
M12×1,25	32 400	30 375	26 325			
M14	40 480	37 950	32 890	24	3,3	2,3
M14×1,5	44 000	41 250	35 750			
M16	55 280	51 825	44 915	32	4,5	3
M16×1,5	58 800	55 125	47 775			
M18	67 600	63 375	54 925	42	6	4,2
M18×1,5	76 000	71 250	61 750			
M20	86 400	81 000	70 200	54	7,5	5,3
M20×1,5	96 000	90 000	78 000			
M22	106 400	99 750	86 450	68	9,5	6,5
M22×1,5	116 800	109 500	94 900			
M24	124 000	116 250	100 750	80	11,5	8
M24×2	135 200	126 750	109 850			
M27	161 600	151 500	131 300	94	13,5	10
M27×2	174 400	163 500	141 700			
M30	197 600	185 250	160 550	108	16	12
M30×2	218 400	204 750	177 450			
M33	244 000	228 750	198 250	122	18	14
M33×2	268 000	251 250	217 750			
M36	287 200	269 250	233 350	136	21	16
M36×3	304 800	285 750	247 650			
M39	343 200	321 750	278 850	150	23	18
M39×3	362 400	339 750	294 450			

NOTE The evaluation of results from the prevailing torque test by statistical process control methods (SPC) has no statistical relevance.

a The clamp force for property class 6 nuts is equal to 80 % of the proof load of property class 6.8 specified in ISO 898-1 for bolts.

b See [Annex B](#).

c The value of the upper limit of the clamp force is equal to 75 % of the proof load, see [Annex B](#).

d The value of the lower limit of the clamp force is equal to 65 % of the proof load, see [Annex B](#).

e The values of prevailing torque for first assembly apply for all metal type nuts only. For prevailing torque non-metallic insert type nuts, the maximum prevailing torques shall be 50 % of the values.

Table 5 — Test clamp force and prevailing torques for prevailing torque nuts of property class 8

Thread <i>D</i> <i>D</i> × <i>P</i>	Test clamp force F_{80}^a N	Clamp force for evaluation of total friction coefficient μ_{tot}^b		Prevailing torque Nm		
		Upper limit F_{75}^c N	Lower limit F_{65}^d N	1 st installation $T_{Fv,max}^e$	1 st removal $T_{Fd,min}$	5 th removal $T_{Fd,min}$
M5	6 584	6 173	5 350	1,6	0,29	0,2
M6	9 280	8 700	7 540	3	0,45	0,3
M7	13 440	12 600	10 920	4,5	0,65	0,45
M8	16 960	15 900	13 780	6	0,85	0,6
M8×1	18 160	17 025	14 755			
M10	26 960	25 275	21 905	10,5	1,5	1
M10×1,25	28 400	26 625	23 075			
M10×1	29 920	28 050	24 310			
M12	39 120	36 675	31 785	15,5	2,3	1,6
M12×1,5	40 880	38 325	33 215			
M12×1,25	42 720	40 050	34 710			
M14	53 360	50 025	43 355	24	3,3	2,3
M14×1,5	58 000	54 375	47 125			
M16	72 800	68 250	59 150	32	4,5	3
M16×1,5	77 520	72 675	62 985			
M18	92 000	86 250	74 750	42	6	4,2
M18×1,5	104 000	97 500	84 500			
M20	117 600	110 250	95 550	54	7,5	5,3
M20×1,5	130 400	122 250	105 950			
M22	145 600	136 500	118 300	68	9,5	6,5
M22×1,5	160 000	150 000	130 000			
M24	169 600	159 000	137 800	80	11,5	8
M24×2	184 000	172 500	149 500			
M27	220 000	206 250	178 750	94	13,5	10
M27×2	238 400	223 500	193 700			
M30	269 600	252 750	219 050	108	16	12
M30×2	298 400	279 750	242 450			
M33	332 800	312 000	270 400	122	18	14
M33×2	365 600	342 750	297 050			
M36	392 000	367 500	318 500	136	21	16
M36×3	415 200	389 250	337 350			
M39	468 800	439 500	380 900	150	23	18
M39×3	494 400	463 500	401 700			

NOTE The evaluation of results from the prevailing torque test by statistical process control methods (SPC) has no statistical relevance.

a The clamp force for property class 8 nuts is equal to 80 % of the proof load of property class 8.8 specified in ISO 898-1 for bolts.

b See [Annex B](#).

c The value of the upper limit of the clamp force is equal to 75 % of the proof load, see [Annex B](#).

d The value of the lower limit of the clamp force is equal to 65 % of the proof load, see [Annex B](#).

e The values of prevailing torque for first assembly apply for all metal type nuts only. For prevailing torque non-metallic insert type nuts, the maximum prevailing torques shall be 50 % of the values.

Table 6 — Test clamp force and prevailing torques for prevailing torque nuts of property class 10

Thread <i>D</i> <i>D</i> × <i>P</i>	Test clamp force F_{80}^a N	Clamp force for evaluation of total friction coefficient μ_{tot}^b		Prevailing torque Nm		
		Upper limit F_{75}^c N	Lower limit F_{65}^d N	1 st installation $T_{Fv,max}^e$	1 st removal $T_{Fd,min}$	5 th removal $T_{Fd,min}$
M5	9 440	8 850	7 670	2,1	0,35	0,24
M6	13 360	12 525	10 855	4	0,55	0,4
M7	19 200	18 000	15 600	6	0,85	0,6
M8	24 320	22 800	19 760	8	1,15	0,8
M8×1	26 000	24 375	21 125			
M10	38 480	36 075	31 265	14	2	1,4
M10×1,25	40 640	38 100	33 020			
M10×1	42 800	40 125	34 775			
M12	56 000	52 500	45 500	21	3,1	2,1
M12×1,5	58 480	54 825	47 515			
M12×1,25	61 120	57 300	49 660			
M14	76 400	71 625	62 075	31	4,4	3
M14×1,5	83 200	78 000	67 600			
M16	104 000	97 500	84 500	42	6	4,2
M16×1,5	111 200	104 250	90 350			
M18	127 200	119 250	103 350	56	8	5,5
M18×1,5	143 200	134 250	116 350			
M20	162 400	152 250	131 950			
M20×1,5	180 800	169 500	146 900	72	10,5	7
M22	201 600	189 000	163 800			
M22×1,5	220 800	207 000	179 400	90	13	9
M24	234 400	219 750	190 450			
M24×2	255 200	239 250	207 350	106	15	10,5
M27	304 800	285 750	247 650			
M27×2	329 600	309 000	267 800	123	17	12
M30	372 800	349 500	302 900			
M30×2	412 000	386 250	334 750	140	19	14
M33	460 800	432 000	374 400			
M33×2	505 600	474 000	410 800	160	21,5	15,5
M36	542 400	508 500	440 700			
M36×3	574 400	538 500	466 700	180	24	17,5
M39	648 000	607 500	526 500			
M39×3	684 000	641 250	555 750	200	26,5	19,5

NOTE The evaluation of results from the prevailing torque test by statistical process control methods (SPC) has no statistical relevance.

a The clamp force for property class 10 nuts is equal to 80 % of the proof load of property class 10.9 specified in ISO 898-1 for bolts.

b See [Annex B](#).

c The value of the upper limit of the clamp force is equal to 75 % of the proof load, see [Annex B](#).

d The value of the lower limit of the clamp force is equal to 65 % of the proof load, see [Annex B](#).

e The values of prevailing torque for first assembly apply for all metal type nuts only. For prevailing torque non-metallic insert type nuts, the maximum prevailing torques shall be 50 % of the values.

Table 7 — Test clamp force and prevailing torques for prevailing torque nuts of property class 12

Thread <i>D</i> <i>D</i> × <i>P</i>	Test clamp force F_{80}^a N	Clamp force for evaluation of total friction coefficient μ_{tot}^b		Prevailing torque Nm		
		Upper limit F_{75}^c N	Lower limit F_{65}^d N	1 st installation $T_{Fv,max}^e$	1 st removal $T_{Fd,min}$	5 th removal $T_{Fd,min}$
M5	11 040	10 350	8 970	2,1	0,35	0,24
M6	15 600	14 625	12 675	4	0,55	0,4
M7	22 400	21 000	18 200	6	0,85	0,6
M8	28 400	26 625	23 075	8	1,15	0,8
M8×1	30 400	28 500	24 700			
M10	45 040	42 225	36 595	14	2	1,4
M10×1,25	47 520	44 550	38 610			
M10×1	50 160	47 025	40 755			
M12	65 440	61 350	53 170	21	3,1	2,1
M12×1,5	68 400	64 125	55 575			
M12×1,25	71 440	66 975	58 045			
M14	89 600	84 000	72 800	31	4,4	3
M14×1,5	96 800	90 750	78 650			
M16	121 600	114 000	98 800	42	6	4,2
M16×1,5	129 600	121 500	105 300			
M18	148 800	139 500	120 900	56	8	5,5
M18×1,5	168 000	157 500	136 500			
M20	190 400	178 500	154 700	72	10,5	7
M20×1,5	211 200	198 000	171 600			
M22	235 200	220 500	191 100	90	13	9
M22×1,5	258 400	242 250	209 950			
M24	273 600	256 500	222 300	106	15	10,5
M24×2	297 600	279 000	241 800			
M27	356 000	333 750	289 250	123	17	12
M27×2	384 800	360 750	312 650			
M30	435 200	408 000	353 600	140	19	14
M30×2	481 600	451 500	391 300			
M33	538 400	504 750	374 400	160	21,5	15,5
M33×2	590 400	553 500	479 700			
M36	633 600	594 000	514 800	180	24	17,5
M36×3	671 200	629 250	545 350			

NOTE The evaluation of results from the prevailing torque test by statistical process control methods (SPC) has no statistical relevance.

^a The clamp force for property class 12 nuts is equal to 80 % of the proof load of property class 12.9 specified in ISO 898-1 for bolts.

^b See [Annex B](#).

^c The value of the upper limit of the clamp force is equal to 75 % of the proof load, see [Annex B](#).

^d The value of the lower limit of the clamp force is equal to 65 % of the proof load, see [Annex B](#).

^e The values of prevailing torque for first assembly apply for all metal type nuts only. For prevailing torque non-metallic insert type nuts, the maximum prevailing torques shall be 50 % of the values.

Table 7 (continued)

Thread <i>D</i> <i>D</i> × <i>P</i>	Test clamp force F_{80}^a N	Clamp force for evaluation of total friction coefficient μ_{tot}^b		Prevailing torque Nm		
		Upper limit F_{75}^c N	Lower limit F_{65}^d N	1 st installation $T_{Fv,max}^e$	1 st removal $T_{Fd,min}$	5 th removal $T_{Fd,min}$
M39	757 600	710 250	615 550	200	26,5	19,5
M39×3	799 200	749 250	649 350			

NOTE The evaluation of results from the prevailing torque test by statistical process control methods (SPC) has no statistical relevance.

a The clamp force for property class 12 nuts is equal to 80 % of the proof load of property class 12.9 specified in ISO 898-1 for bolts.

b See [Annex B](#).

c The value of the upper limit of the clamp force is equal to 75 % of the proof load, see [Annex B](#).

d The value of the lower limit of the clamp force is equal to 65 % of the proof load, see [Annex B](#).

e The values of prevailing torque for first assembly apply for all metal type nuts only. For prevailing torque non-metallic insert type nuts, the maximum prevailing torques shall be 50 % of the values.

9 Test method

9.1 General

The nuts shall be tested as received.

9.2 Proof load test

The proof load test shall be carried out in accordance with ISO 898-2. Additionally, the following applies.

The nut to be tested shall be assembled on a test bolt (see [9.3](#)) or on a hardened steel mandrel. The maximum prevailing torque to assemble the nut through 360° rotation shall be recorded after the first full thread has passed through the prevailing torque feature and assembly continues until three full threads protrude through the nut. For referee test purposes, a hardened steel mandrel shall be used for prevailing torque non-metallic insert type nuts and a test bolt shall be used for prevailing torque all metal type nuts. The maximum prevailing torque occurring during the assembly of the nut on the test bolt or mandrel shall be recorded after the first full form thread has passed through the prevailing torque feature.

A load equal to the specified proof load for the nut, as specified in ISO 898-2, shall be applied through the test bolt or mandrel against the nut-bearing surface in an axial direction and shall be held for 15 s. The nut shall resist this load without thread stripping or rupture. The proof load test is decisive for acceptance.

The maximum prevailing torque occurring during disassembly of the nut after a half-turn to full disengagement measured with the nut in motion shall not exceed the recorded maximum prevailing torque during assembly.

NOTE Any nut used in the prevailing torque test (see [9.3](#)) may be used for the proof load test, as long as the nut threads are not damaged.

9.3 Prevailing torque test

9.3.1 General

The purpose of this test method is to obtain simultaneously on the prevailing torque nuts:

- the functional properties (prevailing torques developed by the nut);

b) the torque/clamp force properties tested in accordance with ISO 16047.

9.3.2 Test apparatus

For test apparatus, see ISO 16047. In addition, the accuracy of prevailing torque measurement shall be $\pm 5\%$ of the value measured.

For the test setup, see [Figure 1](#). Test apparatus shall not generate clamp force during prevailing torque testing.

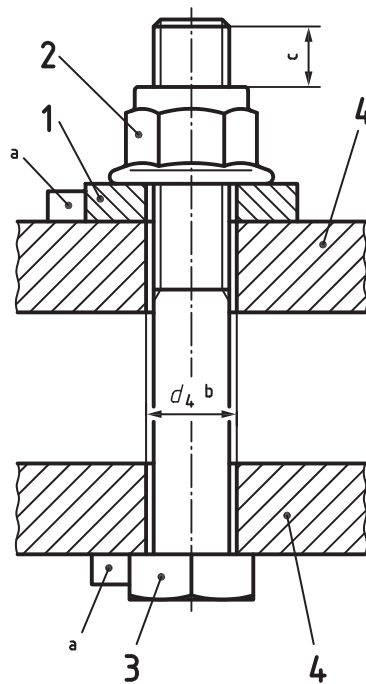

Key

- 1 test-bearing plate/washer
- 2 nut to be tested
- 3 test bolt/screw with thread tolerance class 6g
- 4 test fixture including load cell
- d_4 diameter of the hole of the test fixture
- a Test bearing plate or test washer and bolt head shall be fixed by suitable means to prevent rotation and shall be aligned.
- b d_4 shall be in accordance with ISO 273, fine series.
- c 3 to 5 pitches.

Figure 1 — Test setup and nut when seated

9.3.3 Test parts

For reference bolt/screw and reference test bearing plate/test washer, see ISO 16047. The reference test bearing plate/test washer shall be of type HH, unless otherwise agreed. With the exception of the test mandrel, reference parts shall be used only once.

In case of dispute, the surface condition of the reference test bolt/screw and test bearing plate/washer shall be in accordance with ISO 16047, i.e. plain surface, uncoated and degreased, unless otherwise agreed.

The property class of the test bolt/screw shall be chosen in accordance with [Table 8](#).

Any nut used in the proof load test (see [9.2](#)) shall not be used for the prevailing torque test.

Table 8 — Property classes for the test bolt/screw

Nut to be tested	Corresponding test bolt/screw
Property class	
04	≥ 8.8
5	≥ 8.8
05	≥ 10.9
6	≥ 8.8
8	≥ 8.8
10	≥ 10.9
12	12.9

9.3.4 Test procedure

9.3.4.1 First removal test

This test can be realized automatically on an appropriate testing device or manually with adequate hand tools like torque wrenches and load cells, see [9.3.2](#).

In case of dispute, the automatic mode applies.

Torque/clamp force testing conditions are specified in ISO 16047.

The test bolt/screw is placed in the testing device such that the protrusion through the prevailing torque feature of the nut after seating is in accordance with [Figure 1](#).

The nut to be tested is engaged by hand on the bolt/screw thread until the prevailing torque feature is in contact with the bolt/screw. The end of the test bolt/screw shall not protrude through the nut before testing. The threaded length for tightening shall be three to five pitches in accordance with [Figure 1](#).

The starting point of the installation phase corresponds to the start-up of the tightening device (see point 1 in [Figure 2](#)).

The rotation shall be continuous and uniform from point 1 until the test clamp force, F_{80} , is reached. Values for F_{80} are specified in [Tables 1](#) to [7](#). Torque at clamp force F_{75} shall be recorded and evaluated.

NOTE The F_{80} value provides the shut-down signal for the test device to ensure precise evaluation at F_{75} .

The seating point (see point 3 in [Figure 2](#)) shall be determined. Between point 1 and point 3, the prevailing-on torque, $T_{FV,max}$, (see point 2 in [Figure 2](#)) shall be measured. It shall not exceed the values $T_{FV,max}$ specified in [Tables 1](#) to [7](#).

The nut is then rotated off by the application of a reverse torque until the clamp force in the test bolt/screw is reduced to zero (see point 4 in [Figure 2](#)). The maximum prevailing-off torque, $T_{Fd,max}$, occurring while the nut is rotated through the next 360° of rotation (see point 5 in [Figure 2](#)) shall be measured. This torque shall be equal to, or higher than, the 1st removal prevailing torque value, $T_{Fd,min}$, specified in [Tables 1](#) to [7](#). Point 6 corresponds to the angular position of point 4 minus 360°.

The nut is then disassembled until the initial angular position is reached again (see point 1).

During the removal of the nut, the rotating shall be continuous and uniform from the test clamp force, F_{80} , to point 1.

After the complete removal of the nut, the nut and bolt threads shall not be damaged. In case of dispute, the test bolt shall accept the appropriate ring gauge.

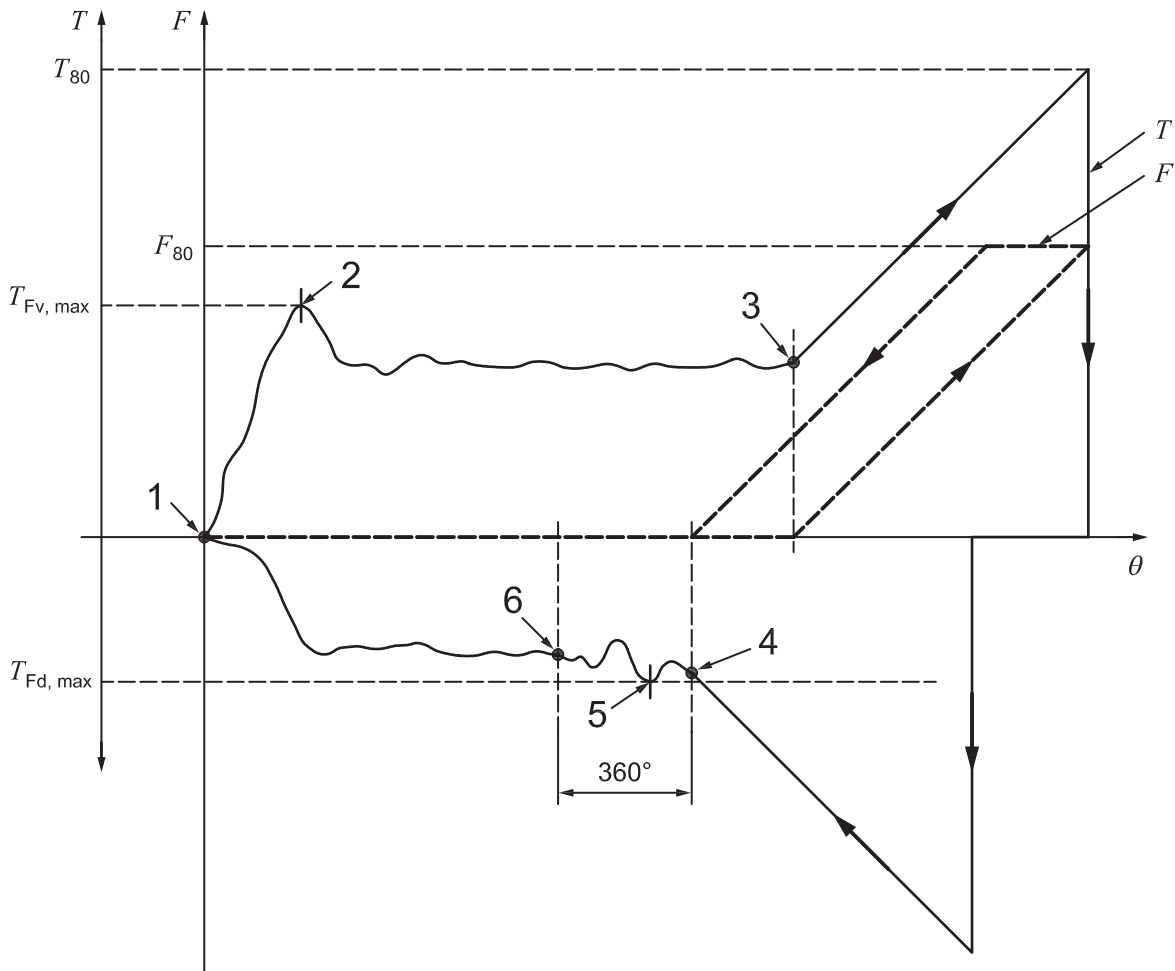

Key

- 1 point where prevailing-on torque occurs first and measurement of T_{Fv} starts
- 2 prevailing-on torque
- 3 seating point, end of measurement of T_{Fv}
- 4 no contact with the test plate/washer, beginning of measurement of T_{Fd}
- 5 prevailing off torque
- 6 end of measurement of T_{Fd}
- F clamp force
- T torque
- θ angle

Figure 2 — Torque/clamp force/angle curve

9.3.4.2 Fifth removal test

For determination of the values for the 5th removal, the procedure in 9.3.4.1 shall be performed four more times between point 1 and point 3 only.

During the 5th removal, the maximum prevailing-off torque occurring while the nut is being rotated through 360° shall be measured in accordance with Figure 2. This torque shall be equal to, or higher than, the 5th removal prevailing torque value as specified in Tables 1 to 7.

After the complete removal of the nut, the nut and bolt threads shall not be damaged. In case of dispute, the test bolt shall accept the appropriate ring gauge.

9.3.5 Test report

See ISO 16047 for the test report content. A reference to this International Standard, i.e. ISO 2320, shall be included in the test report.

The prevailing-on torque, T_{Fv} , and the prevailing-off torque, T_{Fd} , (and, if required, the temperature resistance test result for prevailing torque non-metallic insert type nuts) shall be included in the test report.

Annex A (normative)

Temperature influence on prevailing torques of nuts with non-metallic insert

The use of prevailing torque nuts with non-metallic insert at or near the temperature limits of -50 °C and $+120\text{ °C}$ can reduce the prevailing torque capability and can require the use of an adequate non-metallic material.

This annex specifies a comparative test to show the influence of temperature on the prevailing torque properties. This test may be agreed between customer and supplier, if appropriate.

There is no direct relation between the result of this test and the performance of the nut under actual service conditions.

NOTE It is strongly recommended to develop a test procedure considering actual service conditions, see also ISO 16047:2005, Clause 9.

At ambient temperature (10 °C to 35 °C), the nut shall be assembled on to a test bolt until three to five full threads protrude through the nut but no clamp force is induced.

The assembly shall be placed in a chamber at $+120\text{ °C}$, unless otherwise agreed. After 1 h, it shall be removed from the chamber to cool naturally to ambient temperature.

The assembly shall then be placed in a chamber at -50 °C , unless otherwise agreed. After 1 h, it shall be removed from the chamber to recover naturally to ambient temperature.

With the assembly at ambient temperature, the prevailing-off torque shall be measured between point 4 and point 6 in accordance with [9.3.4.1](#).

The maximum prevailing-off torque measured shall not be lower than the relevant values specified in [Tables 1](#) to [7](#), unless otherwise agreed.

Annex B (informative)

Principles for the evaluation of the total coefficient of friction, μ_{tot}

The tightening process runs up to a test clamp force of 80 % of the proof load of the mating bolt. For evaluation of the coefficient of friction, μ_{tot} , the clamp force is determined in the range of 65 % to 75 % of the proof load value.

The coefficient of friction, μ_{tot} , is calculated as the mean of the coefficients of friction in the range of 65 % to 75 %.

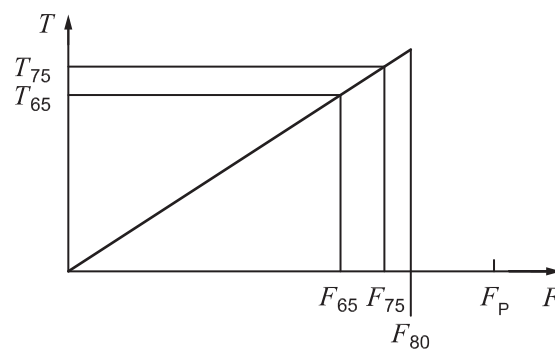

Key

- F_p proof load
- F_{65} lower load limit for the evaluation of the coefficient of total friction at 65 % of F_p
- F_{75} upper load limit for the evaluation of the coefficient of total friction at 75 % of F_p
- F_{80} test clamp force (shut-down value for the tightening process) at 80 % of F_p
- T_{65} lower torque limit for the evaluation of the coefficient of total friction at F_{65}
- T_{75} upper torque limit for the evaluation of the coefficient of total friction at F_{75}

Figure B.1 — Principles for evaluation of the coefficient of friction, μ_{tot}

Annex C (informative)

Test clamp force and prevailing torques for prevailing torque nuts M3 and M4 in property classes 8 and 10

See [Tables C.1](#) and [C.2](#).

Table C.1 — Test clamp force and prevailing torques for prevailing torque nuts of property class 8

Thread <i>D</i>	Test clamp force F_{80}^a N	Clamp force for evaluation of total friction coefficient		Prevailing torque		
		μ_{tot}^b		Nm		
		Upper limit F_{75}^c N	Lower limit F_{65}^d N	1 st installation $T_{Fv,max}^e$	1 st removal $T_{Fd,min}$	5 th removal $T_{Fd,min}$
M3	2 336	2 190	1 898	0,43	0,12	0,08
M4	4 080	3 825	3 315	0,90	0,18	0,12

NOTE The evaluation of results from the prevailing torque test by statistical process control methods (SPC) has no statistical relevance.

^a The clamp force for property class 8 nuts is equal to 80 % of the proof load of property class 8.8 bolts. Proof loads for bolts are specified in ISO 898-1.

^b See [Annex B](#).

^c The value of the upper limit of the clamp force is equal to 75 % of the proof load, see [Annex B](#).

^d The value of the lower limit of the clamp force is equal to 65 % of the proof load, see [Annex B](#).

^e The prevailing torques for first assembly apply for all metal type nuts only. For prevailing torque non-metallic insert type nuts, the maximum torques shall be 50 % of the values.

Table C.2 — Test clamp force and prevailing torques for prevailing torque nuts of property class 10

Thread <i>D</i>	Test clamp force F_{80^a} N	Clamp force for evaluation of total friction coefficient		Prevailing torque Nm		
		μ_{tot}^b		1st installation $T_{Fv,\text{max}}^e$	1st removal $T_{Fd,\text{min}}$	5th removal $T_{Fd,\text{min}}$
		Upper limit F_{75^c} N	Lower limit F_{65^d} N			
M3	3 344	3 135	2 717	0,60	0,15	0,10
M4	5 832	5 468	4 739	1,20	0,22	0,15

NOTE The evaluation of results from the prevailing torque test by statistical process control methods (SPC) has no statistical relevance.

a The clamp force for property class 10 nuts is equal to 80 % of the proof load of property class 10.9 bolts. Proof loads for bolts are specified in ISO 898-1.

b See [Annex B](#).

c The value of the upper limit of the clamp force is equal to 75 % of the proof load, see [Annex B](#).

d The value of the lower limit of the clamp force is equal to 65 % of the proof load, see [Annex B](#).

e The prevailing torques for first assembly apply for all metal type nuts only. For prevailing torque non-metallic insert type nuts, the maximum torques shall be 50 % of the values.

Bibliography

- [1] ISO 68-1, *ISO general purpose screw threads — Basic profile — Part 1: Metric screw threads*
- [2] ISO 261, *ISO general purpose metric screw threads — General plan*
- [3] ISO 262, *ISO general purpose metric screw threads — Selected sizes for screws, bolts and nuts*

British Standards Institution (BSI)

BSI is the national body responsible for preparing British Standards and other standards-related publications, information and services.

BSI is incorporated by Royal Charter. British Standards and other standardization products are published by BSI Standards Limited.

About us

We bring together business, industry, government, consumers, innovators and others to shape their combined experience and expertise into standards-based solutions.

The knowledge embodied in our standards has been carefully assembled in a dependable format and refined through our open consultation process. Organizations of all sizes and across all sectors choose standards to help them achieve their goals.

Information on standards

We can provide you with the knowledge that your organization needs to succeed. Find out more about British Standards by visiting our website at bsigroup.com/standards or contacting our Customer Services team or Knowledge Centre.

Buying standards

You can buy and download PDF versions of BSI publications, including British and adopted European and international standards, through our website at bsigroup.com/shop, where hard copies can also be purchased.

If you need international and foreign standards from other Standards Development Organizations, hard copies can be ordered from our Customer Services team.

Subscriptions

Our range of subscription services are designed to make using standards easier for you. For further information on our subscription products go to bsigroup.com/subscriptions.

With **British Standards Online (BSOL)** you'll have instant access to over 55,000 British and adopted European and international standards from your desktop. It's available 24/7 and is refreshed daily so you'll always be up to date.

You can keep in touch with standards developments and receive substantial discounts on the purchase price of standards, both in single copy and subscription format, by becoming a **BSI Subscribing Member**.

PLUS is an updating service exclusive to BSI Subscribing Members. You will automatically receive the latest hard copy of your standards when they're revised or replaced.

To find out more about becoming a BSI Subscribing Member and the benefits of membership, please visit bsigroup.com/membership.

With a **Multi-User Network Licence (MUNL)** you are able to host standards publications on your intranet. Licences can cover as few or as many users as you wish. With updates supplied as soon as they're available, you can be sure your documentation is current. For further information, email bsmusales@bsigroup.com.

BSI Group Headquarters

389 Chiswick High Road London W4 4AL UK

Revisions

Our British Standards and other publications are updated by amendment or revision.

We continually improve the quality of our products and services to benefit your business. If you find an inaccuracy or ambiguity within a British Standard or other BSI publication please inform the Knowledge Centre.

Copyright

All the data, software and documentation set out in all British Standards and other BSI publications are the property of and copyrighted by BSI, or some person or entity that owns copyright in the information used (such as the international standardization bodies) and has formally licensed such information to BSI for commercial publication and use. Except as permitted under the Copyright, Designs and Patents Act 1988 no extract may be reproduced, stored in a retrieval system or transmitted in any form or by any means – electronic, photocopying, recording or otherwise – without prior written permission from BSI. Details and advice can be obtained from the Copyright & Licensing Department.

Useful Contacts:

Customer Services

Tel: +44 845 086 9001

Email (orders): orders@bsigroup.com

Email (enquiries): cservices@bsigroup.com

Subscriptions

Tel: +44 845 086 9001

Email: subscriptions@bsigroup.com

Knowledge Centre

Tel: +44 20 8996 7004

Email: knowledgecentre@bsigroup.com

Copyright & Licensing

Tel: +44 20 8996 7070

Email: copyright@bsigroup.com



...making excellence a habit.™